

Industriefunkuhren



Technical Manual

Mains Frequency Analysis Board

Model 7515RC

ENGLISH

Version: 02.00 – 05.01.2005

Valid for Devices 7515RC with FIRMWARE Version: **02.xx**
and REMOTE-SOFTWARE Version: **02.xx**

Version number (Firmware / Manual)

THE FIRST TWO DIGITS OF THE VERSION NUMBER OF THE TECHNICAL MANUAL AND THE FIRST TWO DIGITS OF THE FIRMWARE VERSION MUST **COMPLY WITH EACH OTHER**. THEY INDICATE THE FUNCTIONAL CORRELATION BETWEEN DEVICE AND TECHNICAL MANUAL.

THE DIGITS AFTER THE POINT IN THE VERSION NUMBER INDICATE CORRECTIONS IN THE FIRMWARE / MANUAL THAT ARE OF NO SIGNIFICANCE FOR THE FUNCTION.

Downloading Technical Manuals

All current manuals of our products are available free of charge via our homepage on the Internet.

Homepage: <http://www.hopf.com>

E-Mail: info@hopf.com

Symbols and Characters



Operational Reliability

Disregard may cause damages to persons or material.



Functionality

Disregard may impact function of system/device.



Information

Notes and Information.



Safety regulations

The safety regulations and observance of the technical data serve to ensure trouble-free operation of the device and protection of persons and material. It is therefore of utmost importance to observe and compliance with these regulations.

If these are not complied with, then no claims may be made under the terms of the warranty and no liability will be assumed for any ensuing damage.



Safety of the device

This device has been manufactured in accordance with the latest technological standards and approved safety regulations

The device should only be put into operation by trained and qualified staff. Care must be taken that all cable connections are laid and fixed in position correctly. The device should only be operated with the voltage supply indicated on the identification label.

The device should only be operated by qualified staff or employees who have received specific instruction.

If a device must be opened for repair, this should only be carried out by employees with appropriate qualifications or by **hopf** Elektronik GmbH.

Before a device is opened or a fuse is changed all power supplies must be disconnected.

If there are reasons to believe that the operational safety can no longer be guaranteed the device must be taken out of service and labelled accordingly.

The safety may be impaired when the device does not operate properly or if it is obviously damaged.

CE-Conformity



This device fulfils the requirements of the EU directive 89/336/EEG "Electromagnetic compatibility" and 73/23/EEG "Low voltage equipment".

Therefore the device bears the CE identification marking (CE=Communauté Européenne)

CE = Communautés Européennes = European communities

The CE indicates to the controlling bodies that the product complies with the requirements of the EU directive - especially with regard to protection of health and safety for the operator and the user - and may be released for sale within the common markets.

Contents	Page
1 Mains Frequency Analysis Board for 50Hz and 60Hz Public Mains Supplys	7
2 Mains Frequency.....	8
2.1 Functional Schematic of 'RC-Function Board' 7515RC	8
2.2 Mains Frequency Calculation Example.....	8
2.3 Mains Time from Mains Frequency.....	9
2.4 Difference Time between System Time and Mains Time	9
3 'RC-Function Board' 7515RC Design.....	10
3.1 Front Panel.....	10
3.1.1 Send LED.....	10
3.1.2 Pin Assignment for 9-pole SUB-D Female Connectors 1 and 2.....	11
3.1.3 Pin Assignment for 9-pole SUB-D Female Connector 3.....	11
3.1.4 Pin Assignment for 9-pole SUB-D Female Connector 4.....	11
3.2 VG-strip 64-pole connectors (DIN 41612).....	12
3.3 Board 7515RC Assembly Overview.....	13
3.4 Mains Frequency Measurement Connection	13
4 Implementing the 'RC-Function Board' 7515RC in the System 7001RC	14
4.1 Identification of the Board Numbers Available	14
4.2 Setting the Board Number	14
4.3 Installing a new Board 7515RC in the System 7001RC.....	15
4.4 Setting Parameters Activating the 'RC-Function Board' 7515RC in the System 7001RC	16
5 Administration of Board 7515RC	17
5.1 Input Functions for Board 7515RC via the BOARD-SETUP Menu.....	17
5.1.1 Input Interface Parameter COM1 via Parameter Byte 01.....	18
5.1.2 Input Interface Parameter COM2 via Parameter Byte 02 (not activated at present).....	18
5.1.3 Input Parameter Byte 03	19
5.1.3.1 Bit 5 - Nominal Frequency 50Hz or 60Hz.....	19
5.1.4 Input Parameter Byte 04 (no function at present).....	19
5.2 Display and Correction of Measurements via the SPECIAL-BOARD-TIME Menu....	20
5.2.1 Visualization of the Measurements.....	20
5.2.2 Correction of the Mains Time Difference	20
5.2.2.1 Setting the Mains Time Difference to Zero with an External Voltage Reset Pulse.....	21
5.2.2.2 Setting the Mains Time Difference to Zero by System-Reset or after Power Failure	21
6 Signal Outputs	22
6.1 Serial Interfaces	22
6.2 Analogue Measurement Frequency Output (optional).....	23

7 Data Strings	24
7.1 System Time (Identifier F0)	24
7.2 Mains Time (Identifier F1).....	24
7.3 Difference Time (Identifier F2)	25
7.4 Mains Frequency (Identifier F3).....	25
7.5 F7-Master/Slave-String (Identifier F7).....	26
7.5.1 Structure.....	26
7.5.2 Status	27
7.5.3 Example	27
8 Technical Data	28

1 Mains Frequency Analysis Board for 50Hz and 60Hz Public Mains Supplys

The Board 7515RC is a Mains Frequency Analysis Board in eurocard size with 3U/8HP front panel, suitable for monitoring electrical systems. In order to operate the board, a 3U/8HP panel integrated in the system is required, equipped with 3 screw terminals to feed in the electrical supply to be monitored. For this reason, any future upgrading of the system can only be carried out by **hopf** Elektronik GmbH.

Board 7515RC provides a measurement and monitoring system for electrical frequencies between 45 and 65Hz. The mains voltage to be monitored must lie between 90 and 260V AC.

Application areas for Board 7515RC are, for example, mains frequency monitoring in power stations and recording frequency characteristics via connected XY-chart recorders (when the analogue part of Board 7515RC is equipped - option). In addition, the measurement results can be shown on **hopf** large scale display units.

Theoretically, up to 31 boards of type 7515RC can be operated in the system 7001RC. This quantity is limited by the dimensions of the housing. Special designs are available from **hopf** Elektronik GmbH on enquiry.

The following values are calculated on Board 7515RC:

- Mains frequency in mHz
- Difference frequency in mHz
- Mains time from mains frequency in seconds
- Mains time difference (system time to mains time) in milliseconds. This can be set via the system 7001RC (keypad / display or **hopf** 7001RC Remote Software) or set to zero via an external voltage pulse.

Board 7515RC has the following features:

- **Connection**
Connection takes place via four 9-pole SUB-D female connectors (signal output) and three screw terminals (voltage feed).
- **Measurement Output to Large Displays**
One or more **hopf** large scale displays 4985 can be connected directly to the RS422 interface of Board 7515RC, in order to visualize the measurements.
- **Additional Signal Output**
All measurements are also distributed via the internal system bus and can be output as a data string using serial interface boards.
- **Optional Analogue Output for Board 7515RC**
Emission of the difference frequency as an analogue output (current or voltage output) to operate a chart recorder.

The 'Hot Plug' facility enables the Board 7515RC to be removed from and reconnected to the running system 7001RC at any time, without affecting the operation of the other 'Function Boards'. However, it can only be connected at the plug-in point fixed by the mains frequency measurement connection.



For safety reasons, Board 7515RC may only be removed from the running system 7001RC after the mains voltage to be measured has been separated from the supply or has been switched off.

The Mains Frequency Analysis Board 7515RC can be configured via the **hopf** system 7001RC keypad or via the **hopf** 7001RC Remote Software.

2 Mains Frequency

Mains frequency is defined as the frequency of the electrical current available in an electrical power supply. The unit of the frequency is Hertz, abbreviation Hz (1 Hz = 1/sec). Board 7515RC can operate with electrical power supplies with a nominal frequency of 50 Hz or 60 Hz.

2.1 Functional Schematic of 'RC-Function Board' 7515RC

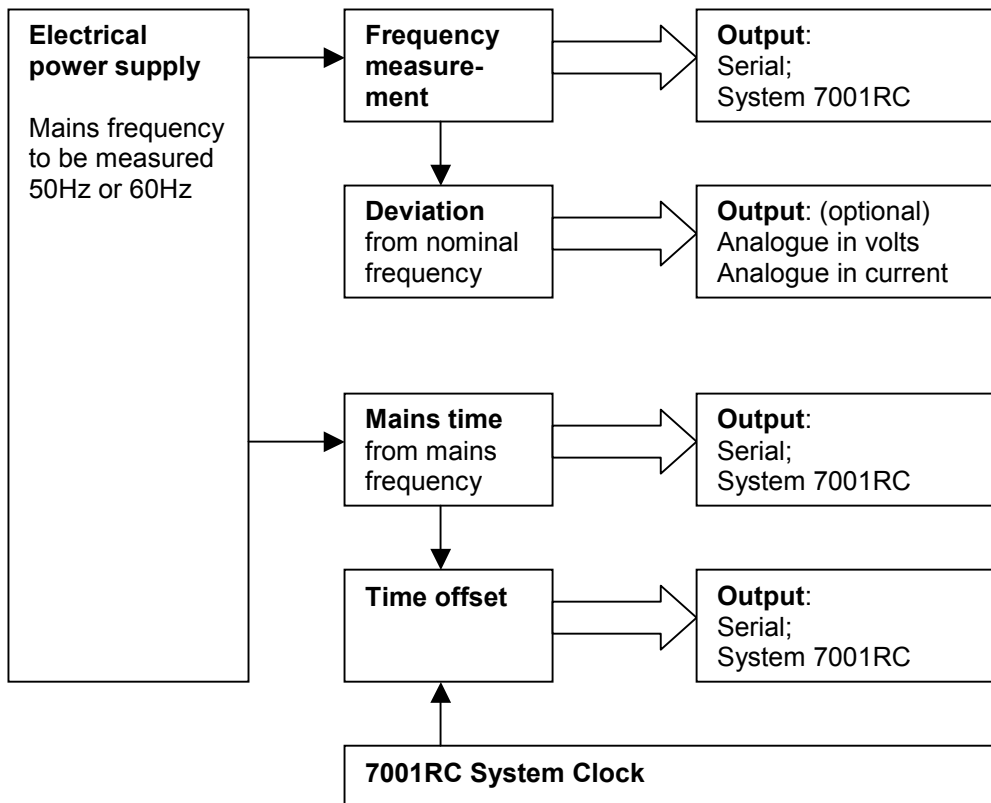

2.2 Mains Frequency Calculation Example

The mains voltage is transformed into a lower voltage via a safety transformer in the input circuit of the 'RC-Function Board' 7515RC and transformed into square waves by a Schmitt-trigger mechanism.

Interference due to high-frequency voltage peaks is filtered by a low-pass filter wired before the Schmitt-trigger.

The pulse width of the square waves is used to calculate the mains frequency. A scan frequency is generated on the 'RC-Function Board' 7515RC from the highly accurate system time base.



The accuracy of the scan frequency is dependent on the system accuracy. Accordingly, the calculation of the mains frequency and the measurements derived from it depend on the system accuracy.

With this scan frequency, a measurement is produced from the sum of 8 mains periods. Therefore, a new measurement is available after approx. 160 msec at a mains frequency of 50 Hz and after approx. 133 msec at a mains frequency of 60 Hz.

After a measurement has been generated, the frequency is calculated from the last 8 measurements by dividing the duration of the period. Therefore, the last 64 mains periods are used for each new frequency calculation.

2.3 Mains Time from Mains Frequency

The 'RC-Function Board' 7515RC can calculate the time from the mains frequency in second steps by counting the mains periods. This time is described as the mains time.

In order to calculate the mains time correctly, attention is to be paid to the correct selection of the nominal frequency (see **Chapter 5.1.3.1 Bit 5 - Nominal Frequency 50Hz or 60Hz**).

2.4 Difference Time between System Time and Mains Time

The difference time between system time and mains time is required for the precise adjustment of the mains frequency, in order to compensate for a difference time (phase offset) caused by frequency fluctuations.

The mains time difference is generated in steps of milliseconds at every mains time second change.

It is possible to synchronize the mains time in the system 7001RC with the system time (see **Chapter 5.2.2 Correction of the**).

3 'RC-Function Board' 7515RC Design

The Board 7515RC has a 3U/8HP front panel for 19" systems with the following components:

3.1 Front Panel

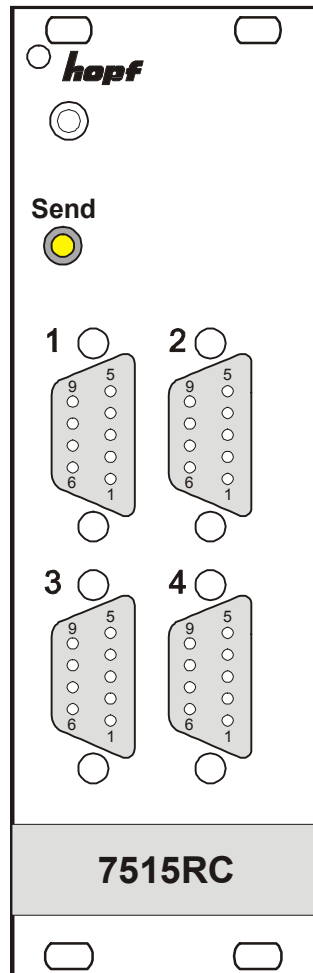

Yellow Send LED

SUB-D female connectors 1+2

SUB-D female connectors 3+4

3.1.1 Send LED

SEND LED	Description
Flashing	Normal condition, indicating access to the internal bus. 'RC-Function Board' 7515RC is installed correctly in the system 7001RC.
Permanently off	'RC-Function Board' 7515RC is not ready for operation.
Permanently on	Fault on 'RC-Function Board' 7515RC.

3.1.2 Pin Assignment for 9-pole SUB-D Female Connectors 1 and 2

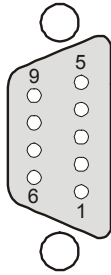

Pin No.	female connector 1 (COM1), female connector 2 (COM2, not implemented)	
1	GND	
2	TxD	RS232
3	RxD	
4	RTS (not implemented)	
5	CTS (not implemented)	
6	TxD + high active	RS422
7	TxD - low active	
8	RxD - low active	
9	RxD + high active	

3.1.3 Pin Assignment for 9-pole SUB-D Female Connector 3

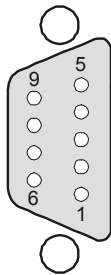

Pin No.	Pulse to set mains time difference to zero
1	Pulse input 1
2	Pulse input 2
3	Pulse input 3
4	not allocated
5	not allocated
6	GND
7	not allocated
8	not allocated
9	not allocated

3.1.4 Pin Assignment for 9-pole SUB-D Female Connector 4

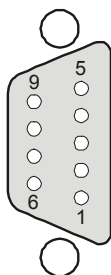

Pin No.	Analogue Measurement Frequency Output (optional)
1	Voltage Output Channel 1
2	Current Output Channel 1
3	GND Channel 1
4	not allocated
5	not allocated
6	Voltage Output Channel 2
7	Current Output Channel 2
8	GND Channel 2
9	not allocated

3.2 VG-strip 64-pole connectors (DIN 41612)

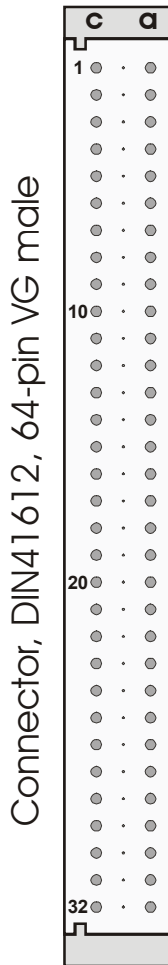

Connector, DIN 41612, 64-pole VG male					
Pin	c		a		Pin
1					1
2	Mains connection L		Mains connection L		2
3					3
4					4
5	Mains connection PE		Mains connection PE		5
6					6
7					7
8	Mains connection N		Mains connection N		8
9					9
10					10
11					11
12					12
13					13
14					14
15					15
16					16
17					17
18					18
19					19
20					20
21	RES / System-Reset				21
22					22
23	SERI / System-Bus		SCLK / Bus pulse		23
24	KHZB / Regulated 1kHz pulse		PPS / Regulated 1Hz pulse		24
25	FROUT		FRIN		25
26					26
27	AROUT		ARIN		27
28					28
29	+12V		+12V		29
30	-12V		-12V		30
31	GND		GND		31
32	+5V DC		VCC / 5Volt		32

3.3 Board 7515RC Assembly Overview

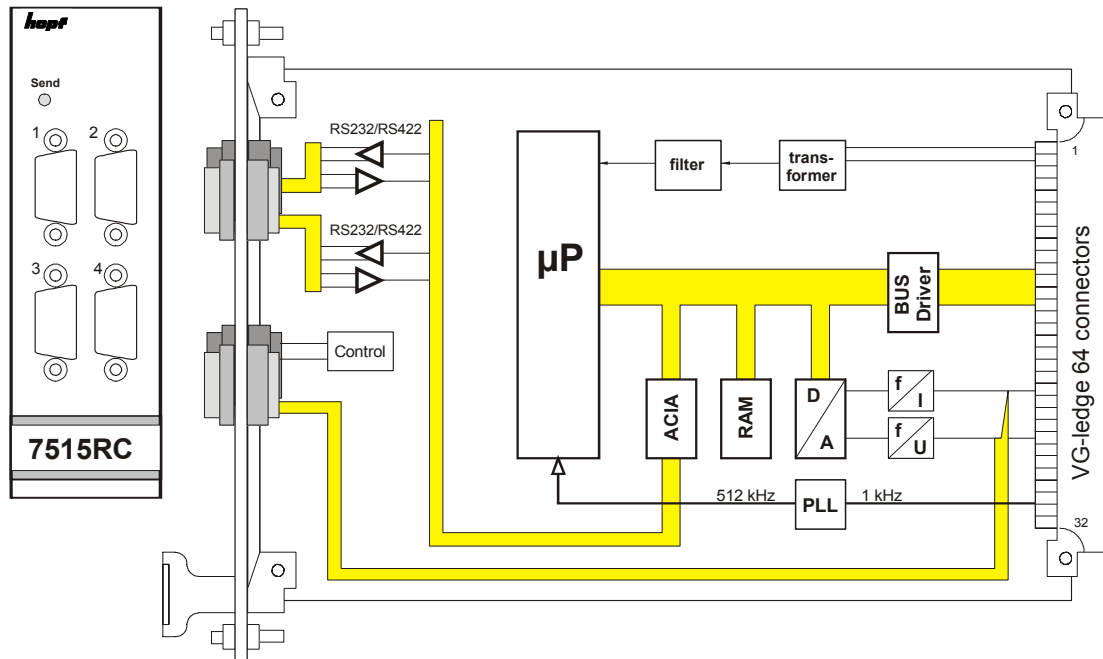

3.4 Mains Frequency Measurement Connection



The mains frequency to be analyzed is fed in via a 3-pole screw terminal for 4mm² cables.

It is identified by L1, PE and N.



The mains frequency measurement connection may only be made by specialist personnel or authorized persons.

The mains frequency measurement connection must be suitably fused (see **Chapter 8 Technical Data**).

4 Implementing the 'RC-Function Board' 7515RC in the System 7001RC



This Chapter describes the implementation of an additional 'RC-Function Board' in the system 7001RC. Generally, all system boards are implemented and pre-configured with the **hopf** default settings on newly delivered systems.

All 'RC-Function Boards' are individually parameterized from the system 7001RC.



Each 'RC-Function Board' is uniquely identified via the Board type and an allocated board number (1-31).

The following steps are required for implementation:

- Identification of the board numbers available
- Setting the board number using DIP-Switch DS1 on the 'RC-Function Board' 7515RC
- Installing the 'RC-Function Board' 7515RC in the system 7001RC
- Setting the 'RC-Function Board' 7515RC parameters
- Activating the 'RC-Function Board' 7515RC via the system 7001RC

4.1 Identification of the Board Numbers Available

The Board numbers allocated so far can be displayed via the **SHOW ALL ADDED SYSTEM-BOARDS** menu. The Board numbers that are not listed for this 'RC-Function Board' type are available for the new 'RC-Function Board' 7515RC.



Boards that are available in terms of hardware, but which have not yet been activated via the system menu, are **not** listed in the **SHOW ALL ADDED SYSTEM-BOARDS** menu. (The "SEND" LED of these Boards does not flash when in operation.)

In order to identify the set Board number, these Boards must be made available externally, in order to identify the set Board number from the DIP switch setting.

4.2 Setting the Board Number

In order to clearly identify the 'RC-Function Board' 7515RC in the system 7001RC, the board number must be defined via the DS1 DIP switch bank. The board number is set as Hex code on **DS1**. Switch 8 is the lowest value bit and switch 1 the highest value bit. The inscription on the DIP switch housing serves to identify switches 1-8. Board numbers can be set from 1 to 31; Board numbers outside this range are not recognized by the system 7001RC.



Under no circumstances may two 'RC-Function Boards' of the same type with the same Board number be installed in one system 7001RC. This leads to undefined errors on both 'RC-Function Boards'.

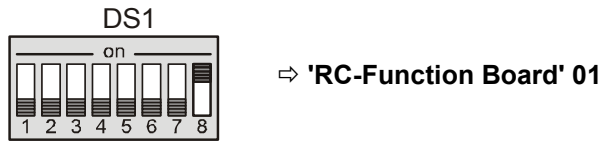

DS1 Pos 4	DS1 Pos 5	DS1 Pos 6	DS1 Pos 7	DS1 Pos 8	Board number in system 7001RC
off	off	off	off	on	1
off	off	off	on	off	2
off	off	off	on	on	3
off	off	on	off	off	4
off	off	on	off	on	5
off	off	on	on	off	6
off	off	on	on	on	7
off	on	off	off	off	8
off	on	off	off	on	9
off	on	off	on	off	10
off	on	off	on	on	11
off	on	on	off	off	12
off	on	on	off	on	13
off	on	on	on	off	14
off	on	on	on	on	15
on	off	off	off	off	16
on	off	off	off	on	17
on	off	off	on	off	18
on	off	off	on	on	19
on	off	on	off	off	20
on	off	on	off	on	21
on	off	on	on	off	22
on	off	on	on	on	23
on	on	off	off	off	24
on	on	off	off	on	25
on	on	off	on	off	26
on	on	off	on	on	27
on	on	on	off	off	28
on	on	on	off	on	29
on	on	on	on	off	30
on	on	on	on	on	31

4.3 Installing a new Board 7515RC in the System 7001RC

In order to install a new Board 7515RC, a free 8HP extension slot (slot with board guide bars and VG-strip installed in the system bus) must be available. This information can be obtained from the assembly drawing supplied. In addition, a 3U/8HP panel with 3 screw terminals to feed in the mains voltage to be monitored is required to be integrated in the base system, in order for the board to operate. For this reason, subsequent upgrading of the system can only be carried out by **hopf** Elektronik GmbH.

If a free extension slot is not available, this can usually be retrofitted. Please contact **hopf** Elektronik GmbH.



If a Board 7515RC with analogue output (optional) is to be added to system 7001RC, a system-internal power supply unit with $\pm 12V$ DC output is also required.

Further information concerning the installation of 'RC-Function Boards' can be found in the system 7001RC technical manual.

4.4 Setting Parameters Activating the 'RC-Function Board' 7515RC in the System 7001RC

The following steps are required to activate the 'RC-Function Board' 7515RC:



To avoid undesirable output behaviour of the 'RC-Function Board' 7515RC it is first parameterized and then activated by switching it into the monitoring system.

- In the **BOARD-SETUP** menu, sub-heading **ADD SYSTEM-BOARDS Y/N**, log on the newly installed 'RC-Function Board' 7515RC.
- In the **BOARD-SETUP** menu, sub-heading **SET SYSTEM BOARDS PARAMETER** parameterize the 'RC-Function Board' 7515RC. (see **Chapter 5 Administration of Board 7515RC**).
- In the **BOARD-SETUP** menu, sub-heading **SET SYSTEM BOARDS TO MONITORING-MODE OR IDLE-MODE Y/N** install the newly implemented 'RC-Function Board' 7515RC into the monitoring system.



The menu functions:

- **ADD SYSTEM-BOARDS Y/N** and
- **SET SYSTEM BOARDS TO MONITORING-MODE OR IDLE-MODE Y/N**

can be consulted in the system 7001RC technical manual.

5 Administration of Board 7515RC

The base system 7001RC specification serves as the basis for configuration. The following will cover only the inputting of the values that can be found under menu heading **BOARD-SETUP : 4**.



All parameters can also be activated in the system 7001RC using the corresponding **hopf** 7001RC Remote Software (see **hopf** 7001RC Remote Software technical manual).



In order for the system 7001RC to accept the newly configured parameters, the **SET SYSTEM-BOARDS PARAMETER** menu must be confirmed by pressing the **ENT** key.

5.1 Input Functions for Board 7515RC via the BOARD-SETUP Menu

The input and display functions of the board parameters are called up in menu heading **BOARD-SETUP : 4**.

- with **ENT** key ⇒ Main menu
- with **4** key ⇒ Board setup
- with **N** key ⇒ Scroll to menu heading:

```

SET SYSTEM-BOARDS PARAMETER Y / N
  
```

Select with key **Y**

Search for 'RC-Function Board' to be parameterized with key **N** and select with key **Y**

Example display:

```

PARAMETER BOARD 03 OF 25 7515 NR.: 04
STATUS: M / - BOARDNAME: "FREQUENZ" SET > Y / N
  
```

- PARAMETER BOARD 03 OF 25** ⇒ 'RC-Function Board' **03** of **25** implemented
- 7515 NR.: 04** ⇒ Board type **7515RC** with Board number **04**
- STATUS: M / -** ⇒ **M** = Monitoring / **-** = Operating without error
- I / E** **I** = No monitoring / **E** = Board error
- BOARDNAME:" FREQUENZ "** ⇒ **FREQUENZ** Board name freely selected by customer

5.1.1 Input Interface Parameter COM1 via Parameter Byte 01

Parameter Byte 01 sets the serial parameters for the COM1 interface on the 9-pole SUB-D female connector 1 on the front panel of Board 7515RC.

Parameter Byte 01 is shown on the upper line with its currently set values.

```

B . 7 5 1 5   N O . : 0 4   O L D :   B Y T E   0 1   > 0 0 0 0 0 1 1 0 <
B Y T E   =   B I T   7 . . 0   N E W :   B Y T E   0 1   > ~ ~ ~ ~ ~ ~ ~ ~ <
    
```

For the purposes of manipulation, the individual bits of the new byte are to be entered on the second line using "0" and "1". The Parameter Byte has always to be entered completely and confirmed with the **ENT** key.

The bits of the Parameter Byte are numbered in descending order:

```

B Y T E   0 1   > 7 6 5 4 3 2 1 0 <
    
```

Bit 7			No function at present
0			For compatibility reasons this bit should be set to 0 (default setting)
Bit 6			Data Bits
0			8
1			7
Bit 5	Bit 4	Parity	
0	0	None	
0	1	None	
1	0	Even	
1	1	Odd	
Bit 3			Stop Bit
0			1
1			2
Bit 2	Bit 1	Bit 0	Baud rate
0	0	0	150
0	0	1	300
0	1	0	600
0	1	1	1200
1	0	0	2400
1	0	1	4800
1	1	0	9600
1	1	1	19200

5.1.2 Input Interface Parameter COM2 via Parameter Byte 02 (not activated at present)

Parameter Byte 02 sets the serial parameters for the COM2 interface on the 9-pole SUB-D female connector 2 on the front panel of Board 7515RC (not activated at present).

Parameter Byte 02 is shown on the upper line with its currently set values.

```

B . 7 5 1 5   N O . : 0 4   O L D :   B Y T E   0 2   > 0 0 0 0 0 0 0 0 <
B Y T E   =   B I T   7 . . 0   N E W :   B Y T E   0 2   > ~ ~ ~ ~ ~ ~ ~ ~ <
    
```

For the purposes of manipulation, the individual bits of the new byte are to be entered on the second line using "0" and "1". The complete Parameter Byte must always be recorded and confirmed with the **ENT** key.

The bits of the Parameter Byte are numbered in descending order:

BYTE 02 > 7 6 5 4 3 2 1 0 <

Bits 7- 0	No function at present
0	For compatibility reasons these bits should be set to 0 (default setting)

5.1.3 Input Parameter Byte 03

Parameter Byte 03 is shown on the upper line with its currently set values.

B . 7 5 1 5 NO . : 0 4 OLD : BYTE 0 3 > 0 0 0 0 0 0 0 0 <
BYTE = BIT 7 . . 0 NEW : BYTE 0 3 > ~ ~ ~ ~ ~ ~ ~ ~ <

For the purposes of manipulation, the individual bits of the new byte are to be entered on the second line using "0" and "1". The complete Parameter Byte must always be recorded and confirmed with the **ENT** key.

The bits of the Parameter Byte are numbered in descending order:

BYTE 03 > 7 6 5 4 3 2 1 0 <

Bits 7- 1	No function at present
0	For compatibility reasons these bits should be set to 0 (default setting)
Bit 0	Nominal frequency of the mains frequency
0	50Hz
1	60Hz

5.1.3.1 Bit 5 - Nominal Frequency 50Hz or 60Hz

The nominal frequency of 50Hz or 60Hz is to be set for the calculations, dependent on the mains frequency.

5.1.4 Input Parameter Byte 04 (no function at present)

Parameter Byte 04 is shown on the upper line with its currently set values.

B . 7 5 1 5 NO . : 0 4 OLD : BYTE 0 4 > 0 0 0 0 0 0 0 0 <
BYTE = BIT 7 . . 0 NEW : BYTE 0 4 > ~ ~ ~ ~ ~ ~ ~ ~ <

For the purposes of manipulation, the individual bits of the new byte are to be entered on the second line using "0" and "1". The complete Parameter Byte must always be recorded and confirmed with the **ENT** key.

The bits of the Parameter Byte are numbered in descending order:

BYTE 04 > 7 6 5 4 3 2 1 0 <

Bits 7 - 0	No function at present
0	For compatibility reasons these bits should be set to 0 (default setting)

5.2 Display and Correction of Measurements via the SPECIAL-BOARD-TIME Menu

The input and display functions of the mains time difference are called up under the menu heading **SPECIAL BOARD TIME: 5**.

- with key ⇒ Main menu
- with key ⇒ SPECIAL BOARD TIME
- with key ⇒ Scroll until required 'RC-Function Board' 7515RC appears

```
B . 7 5 1 5  N O . : 0 4  B O A R D N A M E : " F R E Q U E N Z "   Y / N
```

Select the required 'RC-Function Board' 7515RC with the key.

5.2.1 Visualization of the Measurements

After selecting the 'RC-Function Board' 7515RC required, its current mains time, mains time difference, mains frequency and the system time are shown on the display:

```
B . 7 5 1 5  N O : 0 4  G R D : 1 3 : 3 3 : 2 3 . 9 3 0  t : + 2 0 . 9 3 0
5 0 . 0 4 1 H Z  S Y S - T I M E : 1 3 : 3 3 : 0 3 . 0 0 0  t : . . . .
```

Line 1

- B.7515 NO:04** ⇒ 'RC-Function Board' identification
- GRD:13:33:23.930** ⇒ Current mains time
- t:+20,930** ⇒ Current mains time difference with seconds, milliseconds and operational sign

Line 2

- 50.041Hz** ⇒ Mains frequency measured
- SYS-TIME:13:33:03.000** ⇒ Current system time
- t:____** ⇒ Input of new mains time difference with seconds, milliseconds and operational sign

5.2.2 Correction of the Mains Time Difference

It is possible to input the mains time difference manually in the range from +99.999s to -99.999s for certain applications. For precise manipulation, this is to be recorded with operational signs beginning in seconds and milliseconds. If the mains time difference is to be set to zero, both "+" and "-" can be entered for the operational sign. The input is to be confirmed with the key.

The following options are available to synchronize the mains time in the system 7001RC with the system time:

- By entering the mains time difference on the system 7001RC keypad and display
- By entering the mains time difference using **hopf** 7001RC Remote Software
- The mains time difference is set to +00.00.00.000 with an external voltage pulse (falling edge)
- The mains time difference is set to +00.00.00.000 after a System-Reset or power failure



All parameters can also be activated in the system 7001RC using the corresponding **hopf** 7001RC Remote Software (see **hopf** 7001RC Remote Software technical manual).

5.2.2.1 Setting the Mains Time Difference to Zero with an External Voltage Reset Pulse

A further option for synchronizing the mains time is via a master computer or controller by means of a potential-separated voltage pulse. This pulse is supplied to the 'RC-Function Board' 7515RC via the 9-pole SUB-D female connector 3 (For pin assignment see **Chapter 3.1.3 Pin Assignment for 9-pole SUB-D Female Connector** 3). The pulse amplitude can take place at 3 different voltage levels (see **Chapter 8 Technical Data**).

5.2.2.2 Setting the Mains Time Difference to Zero by System-Reset or after Power Failure

The mains time is automatically synchronized to the system time with a mains time difference = +00.000 seconds after a System-Reset or power failure of the system 7001RC.

6 Signal Outputs

The measurements such as frequency, mains time etc. can be output from Board 7515RC via the serial interface COM1 or using additional system components. The difference frequency can also be emitted via analogue outputs (option).

Since the measurements of the Board 7515RC are calculated by averaging, the Board 7515RC requires a short transient time until correct values are emitted. For this reason, the following operating conditions may lead to false measurements in the short term:

- System switch-on:
Incorrect measurement frequencies are calculated for approx. 4 seconds after switching the system on when measurement voltage is already present.
- Switching on the voltage to be analyzed:
Incorrect measurement frequencies are calculated for approx. 4 seconds after applying or switching on the measurement voltage.
- Synchronization:
If the system 7001RC has not been radio-synchronous for a lengthy period, it may arise that 00Hz is emitted for the mains frequency for a period of 1 second upon synchronization.

6.1 Serial Interfaces

The individual measurements can be accessed via serial strings output via the COM1 interface. Output takes place at both RS232 and RS422 levels. In doing so, a certain identifier is assigned to each measurement value (system time, difference time etc.), so that only the required values can be filtered out of the string.



Due to the fact that the data quantity is transferred every second, a baud rate of ≥ 2400 baud should be selected, since otherwise the data is transferred incompletely.

For the **hopf** large scale display 4985, the strings can be filtered out on the basis of the identifiers, so that the individual measurements can be shown. If several large scale displays 4985 are switched in sequence (RS422-level only), each large scale display can show a different measurement due to the coding.

The following data strings are available for the individual measurements:

Identifier	String	Construction	Max. resolution
F0	System time	Sy 12:34:56	Seconds
F1	Mains time	N1 12:34:56	Seconds
F2	Difference time (positive)	t + 00:00:00,056	Milliseconds
F3	Frequency (50Hz / 60Hz)	f1 50,001	Millihertz
F7	Synchronization via F7-Master/Slave-String	hr min sec dow Da Mo Yr	Seconds

The exact string structure is described in **Chapter 7 Data Strings**.



The strings are output every second, with the exception of the F7-Master/Slave-String, which is transmitted on the 59th second of every minute.

6.2 Analogue Measurement Frequency Output (optional)

As an option, two analogue output channels with different resolutions and the possibility to display the maximum difference frequency are available for long-term recording (such as XY chart recorders). Both channels can be configured independently at the factory as voltage or current outputs.

The analogue output of the difference frequency takes place via the 9-pole SUB-D female connector 4 in the front panel of the Board 7515RC (see **Chapter 3.1.4 Pin Assignment for 9-pole SUB-D Female Connector 4**).

Channel 1 can present larger difference frequencies than Channel 2, for this reason the resolution of the difference frequency is smaller. For more details of the output ranges and resolutions see **Chapter 8 Technical Data**.



A system-internal power supply unit with $\pm 12\text{V}$ DC output is required to operate a Board 7515RC with analogue output in the system 7001RC.

7 Data Strings

7.1 System Time (Identifier F0)

Character No.	Meaning	Hex-Value
1	STX (start of text)	\$02
2	"F" ASCII F	\$46
3	"0" ASCII 0	\$30
4	"S" ASCII S	\$53
5	"y" ASCII y	\$79
6	Space	\$20
7	Tens hour	\$30-32
8	Unit hour	\$30-39
9	":" Colon	\$3A
10	Tens minute	\$30-35
11	Unit minute	\$30-39
12	":" Colon	\$3A
13	Tens second	\$30-36
14	Unit second	\$30-39
15	CR (carriage return)	\$0D
16	ETX (end of text)	\$03

7.2 Mains Time (Identifier F1)

Character No.	Meaning	Hex-Value
1	STX (start of text)	\$02
2	"F" ASCII F	\$46
3	"1" ASCII 1	\$31
4	"N" ASCII N	\$4E
5	"1" ASCII 1	\$31
6	Space	\$20
7	Tens hour	\$30-32
8	Unit hour	\$30-39
9	":" Colon	\$3A
10	Tens minute	\$30-35
11	Unit minute	\$30-39
12	":" Colon	\$3A
13	Tens second	\$30-36
14	Unit second	\$30-39
15	ETB (end of block)	\$17
16	ETX (end of text)	\$03

7.3 Difference Time (Identifier F2)

Character No.	Meaning	Hex-Value
1	STX (start of text)	\$02
2	"F" ASCII F	\$46
3	"2" ASCII 2	\$30
4	"t" ASCII t	\$53
5	DEL (Delete)	\$7F
6	DEL (Delete)	\$7F
7	Operational sign (+/-)	\$2B-2D
8	DEL (Delete)	\$7F
9	DEL (Delete)	\$7F
10	Tens hour	\$30-32
11	Unit hour	\$30-39
12	":" Colon	\$3A
13	Tens minute	\$30-35
14	Unit minute	\$30-39
15	":" Column	\$3A
16	Tens second	\$30-36
17	Unit second	\$30-39
18	CR (carriage return)	\$0D
19-23	5 * Space	\$20
24	Hundreds millisecond	\$30-39
25	Tens millisecond	\$30-39
26	Unit millisecond	\$30-39
27	ETB (end of block)	\$17
28	ETX (end of text)	\$03

7.4 Mains Frequency (Identifier F3)

Character No.	Meaning	Hex-Value
1	STX (start of text)	\$02
2	"F" ASCII F	\$46
3	"3" ASCII 3	\$33
4	"f" ASCII f	\$66
5	"1" ASCII 1	\$31
6	Space	\$20
7	Frequency tens	\$30-39
8	Frequency unit	\$30-39
9	"," Comma	\$2C
10	Frequency 1/10	\$30-39
11	Frequency 1/100	\$30-39
12	Frequency 1/1000	\$30-39
13	Space	\$20
14	"H" ASCII H	\$48
15	"z" ASCII z	\$7A
16	ETB (end of block)	\$17
17	ETX (end of text)	\$03

7.5 F7-Master/Slave-String (Identifier F7)

The large display 4985 can be synchronized to the Master System time data with the F7-Master/Slave-String. The difference time of the base system is also transferred in the data string, so that the UTC time can also be displayed with the correct difference to local time.

The string is transmitted in the 59th second together with the data of the next full minute. The end character "ETX" takes place on the exact second change and updates the data on the large display.

The F7-Master/Slave-String transmits:

- Local time (hour, minute, second)
- Date (day, month, year [2-digit])
- Difference time - Local time to UTC time (hour, minute)
- Day of the week
- Status information (announcement of a ST/WT-changeover, announcement of a leap second, reception status of the F7-Master/Slave-String source)

7.5.1 Structure

Character No.	Meaning	Hex-Value
1	STX (start of text)	\$02
2	"F" ASCII F	\$46
3	"7" ASCII 7	\$37
4	status	\$30-39, \$41-46
5	day-of-week	\$31-37
6	tens hour	\$30-32
7	unit hour	\$30-39
8	tens minute	\$30-35
9	unit minute	\$30-39
10	tens second	\$30-36
11	unit second	\$30-39
12	tens day	\$30-33
13	unit day	\$30-39
14	tens month	\$30-31
15	unit month	\$30-39
16	tens year	\$30-39
17	unit year	\$30-39
18	difference time tens hour / operational sign	\$30-31, \$38-39
19	difference time unit hour	\$30-39
20	difference time tens minute	\$30-35
21	difference time unit minute	\$30-39
22	CR (carriage return)	\$0D
23	LF (line feed)	\$0A
22	ETX (end of text)	\$03

The difference time in hours and minutes is transmitted after the year. The transfer takes place in BCD. The difference time can be max. ± 11.59 hours.

The operational sign is shown as the highest bit in the Tens Hours:

Logic **1** = Local time is behind UTC

Logic **0** = Local time is ahead of UTC

Example:

Data String	Tens Diff.-Time	Difference Time
(STX)F783123456030196 <u>0</u> 300(LF)(CR)(ETX)	<u>0000</u>	- 03:00h
(STX)F783123456030196 <u>1</u> 100(LF)(CR)(ETX)	<u>0001</u>	- 11:00h
(STX)F783123456030196 <u>8</u> 230(LF)(CR)(ETX)	<u>1000</u>	+ 02:30h
(STX)F783123456030196 <u>9</u> 100(LF)(CR)(ETX)	<u>1001</u>	+ 11:00h

7.5.2 Status

Nibble	b3	b2	b1	b0	Meaning
Status	x	x	x	0	No ST/WT-changeover announcement
	x	x	x	1	ST/WT-changeover announcement
	x	x	0	x	Wintertime (WT)
	x	x	1	x	Summertime (ST)
	x	0	x	x	No leap second announcement
	x	1	x	x	Leap second announcement
	0	x	x	x	Quartz operation
	1	x	x	x	Radio operation
Nibble	b3	b2	b1	b0	Meaning
Day of the Week	0	0	0	1	Monday
	0	0	1	0	Tuesday
	0	0	1	1	Wednesday
	0	1	0	0	Thursday
	0	1	0	1	Friday
	0	1	1	0	Saturday
	0	1	1	1	Sunday

7.5.3 Example

(STX)F7831234560301968230(LF)(CR)(ETX)

- Radio operation
- No announcement
- Wintertime
- It is Wednesday 03.01.96 - 12:34:56 o'clock
- The difference time to UTC is + 2.30 hours

8 Technical Data

Power Supply

Standard version: 5V DC via internal System Bus 7001RC
 with optional analogue output: $\pm 12V$ DC via internal System Bus 7001RC

Power Consumption

with/without optional analogue output: 260mA

Mains Frequency

Mains monitoring voltage input: 90 - 260V AC
 Mains fuse: 260V / 1A
 Frequency ranges:
 Nominal frequency 50Hz 45 - 55 Hz
 Nominal frequency 60Hz 55 - 65 Hz
 Safety transformer Converts to max. 8.5V AC, internal to Board
 Resolution: ± 1 mHz
 Measurement inaccuracy: Resolution + system accuracy (see system 7001RC technical manual)

Difference Time

Measurement accuracy: System accuracy ± 1 msec
 Mains time difference: Max. ± 99.999 sec

Voltage-Reset Pulse

Pulse input 1: TTL-level
 Pulse input 2: 12V - 24V DC
 Pulse input 3: 18V - 36V DC
 Pulse length: min. 0.5 sec
 Trigger edge: Falling edge

Analogue Outputs (optional)

Channel 1	Range	Resolution
Voltage output 1	+5Hz = +2.5V / -5Hz = -2.5V	2mHz / mV
Current output 1	+5Hz = +1mA / -5Hz = -1mA	5mHz / μ A
Channel 2	Range	Resolution
Voltage output 2	+0.5Hz = +2.5V / -0.5Hz = -2.5V	0.2mHz / mV
Current output 2	+0.5Hz = +1mA / -0.5Hz = -1mA	0.5mHz / μ A

Special designs:

Hardware and software can be modified on request to meet specific customer requirements.



The **hopf** Company reserves the right to modify hardware and software at any time.