

Technical Description

Interface Board
7201/7221



Safety information

The safety regulations and technical data are important for the smooth running of the devices and the protection of people and equipment. Strict compliance with these regulations is required. In case of non-compliance with these regulations the guarantee and warranty claims for the device and possible consequential damage expire.

Safety of the Devices

The production of this device follows the latest technological standards and safety regulations.

The device must not be assembled by anyone but trained personnel. Please make sure that all the connected cables are laid and fixed properly. The device is to be run with the supply voltage stated on the identification plate only.

Only trained personnel or specialists may operate the device.

Repair on opened devices must not be carried out by anyone but specially trained staff or by the **hopf** company.

If the maintenance work requires the opening of a device or if a fuse needs changing the device must be separated from all voltage supplies.

If there are reasons to believe that the operational safety can no longer be guaranteed the device must be taken out of service and labelled accordingly. The safety may be impaired when the device does not operate properly or if it is obviously damaged.

hopf Elektronik GmbH

Nottebohmstr. 41 58511 Lüdenscheid
Postfach 1847 58468 Lüdenscheid

Tel.: ++49 (0)2351 / 9386-86

Fax: ++49 (0)2351 / 9386-93

Internet: <http://www.hopf.com>

e-mail: info@hopf.com

CONTENTS	Page
1 General	5
1.1 Interface Board 7201	5
1.1.1 Functional Description	5
1.1.2 Specifications	5
1.1.3 Hardware-configuration - Board 7201	6
1.1.4 Pin Assignment - Board 7201	7
1.1.5 Technical Data - Board 7201	8
1.1.6 Block Diagram - Board 7201	8
1.2 Interface Board 7221	9
1.2.1 Functional Description	9
1.2.2 Specifications	9
1.2.3 Hardware-configuration - Board 7221	10
1.2.4 Pin Assignment - Board 7221	11
1.2.5 Technical Data - Board 7221	12
1.2.6 Block Diagram - Board 7221	12
2 The transmitted Data Strings	13
2.1 Data Format of the Serial Transmission	14
2.2 Serial Request	14
2.3 Selection of the Transmission Format by means of DIP-switch SW1	15
2.3.1 Output Local Time, Standard Time or UTC	15
2.3.2 Setting the Word Length	15
2.3.3 Setting the Parity-Mode of the Transmission	15
2.3.4 Setting the Stop Bits	15
2.3.5 Setting the Baud rate	15
3 The different Data Strings	16
3.1 Data String 7001/6021	16
3.1.1 Data String 7001/6021 time and date (standard)	16
3.1.2 Data String 7001/6021 time only	16
3.1.3 Data String 7001/6021 Status and Day of the Week Nibble	17
3.1.4 Example of transmitted Data String 7001/6021	17
3.2 Data String 5500	18
3.2.1 Data String 5500 Time and Date	18
3.2.2 Data String 5500 Time only	18
3.2.3 Data String 5500 Status and Day of the Week Nibble	19
3.2.4 Example of a transmitted Data String 5500	19
3.3 Data String 5050	20
3.3.1 Data String 5050 Time and Date	20
3.3.2 Data String 5050 Time only	21
3.3.3 Data String 5050 Status and Day of the Week Nibble	21
3.3.4 Example of a transmitted Data String 5050	21
3.4 Data String MADAM-S	22
3.4.1 Required setting in case of output MADAM-S	24
3.4.2 Data String MADAM-S Status Nibble	24
3.5 Data String SINEC H1	25
3.5.1 Status in the Data String SINEC H1	26
3.5.2 Example of a transmitted Data String SINEC H1	26
3.5.3 String request	26
3.6 Data String DCF-Slave	27
3.6.1 Status in the Data String DCF-Slave	27
3.6.2 Example of a transmitted Data String DCF-Slave	28
3.6.3 Set-up	28

CONTENTS	Page
3.7 Data String UTC-Slave	29
3.7.1 Status in the Data String UTC-Slave	30
3.7.2 Setting	30
3.8 Data String T-String	31
3.8.1 Example of a transmitted Data String T-string	31
3.9 Data String Date / Time	32
3.9.1 Data String Date / Time - date and time	32
3.9.2 Example of transmitted Data String - date / time	32
3.10 SINEC H1 Extended	33
3.10.1 Status in the Data String SINEC H1 Extended	34
3.10.2 Example of a Transmitted Data String SINEC H1 Extended	34
3.11 Data String 2000	35
3.11.1 Data String 2000 Time and Date with a 4 Digit Year Output	35
3.11.2 Data String 2000 Status and Day of the Week Nibble	36
3.11.3 Example of transmitted Data String 2000	36
3.12 Data String Sysplex Timer Model 1+2	37
3.12.1 Status in the Data String Sysplex Timer Model 1+2	38
3.12.2 Example of a transmitted Data String Sysplex Timer 1+2	38
3.13 Data String for use with NTP (Network Time Protocol)	39
3.14 Data String TimeServ for the Operating System Windows NT	40
3.15 Data String Sicomp M	41
3.15.1 Status in the Data String Sicomp M	42
3.16 Data String H&B	43
3.16.1 Data String H&B Status and Day of the Week Nibble	44
3.16.2 Example of a transmitted Data String H&B	44
3.17 Data String Master/Slave	45
3.17.1 Status in the Data String Master-Slave	46
3.17.2 Example of a Transmitted Data String Master-Slave	46
3.17.3 Settings	46
3.18 Data String with Microsecond	47
3.19 Data String 23RC20	49
3.19.1 Status in the Data String 23RC20	49
3.20 Data String ABB-SPA Seconds-Clock	50
3.20.1 Seconds String	50
3.20.2 Time Data String Date and Time	51
3.21 MDR 2000	52
3.21.1 Status in the Data String MDR 2000	53
3.22 Clock-mouse Data String	54
3.22.1 Status in the Data String Clock-mouse	55
3.23 Clock-mouse Data String with <o><CR>	56
3.24 DCF77-pulse output	57
3.25 NMEA Data String GPRMC	59
3.26 DA55 Data String	61
3.27 OMS Synchro Data String	63
3.28 IRIG J-1x	64
3.28.1 Example of a transmitted Data String IRIG J-1x	64
3.29 CCTV Data String	65
3.30 ABB Master-Clock Data String	66

1 General

There is an Interface board with two different explanations available for the system 7000 and 7001:

- Interface board 7201
- Interface board 7221

1.1 Interface Board 7201

1.1.1 Functional Description

The microprocessor of the interface board 7201 receives the time information via the **hopf** 7001 system bus. The received time can be put out via one of three interfaces. There is a DIP-switch to set cyclic data outputs (e.g. data output every minute).

Baud rate, word length as well as the number of stop bits and parity mode can also be set by means of a DIP-switch. It is possible to set various data strings as output data strings by means of a DIP-switch.

1.1.2 Specifications

- data output via: RS232c (V.24), RS422c (V.11), TTY (20 mA passive)
- baud rate :150 - 19200 baud, TTY (max. 9600 baud, recommended: max. 2400 baud)
- various output strings can be set by means of DIP-Switch (e.g. output UTC time).
- Indication of internal clock status in the status byte of the data string.
- Potential separate RS232c- and RS422 interface

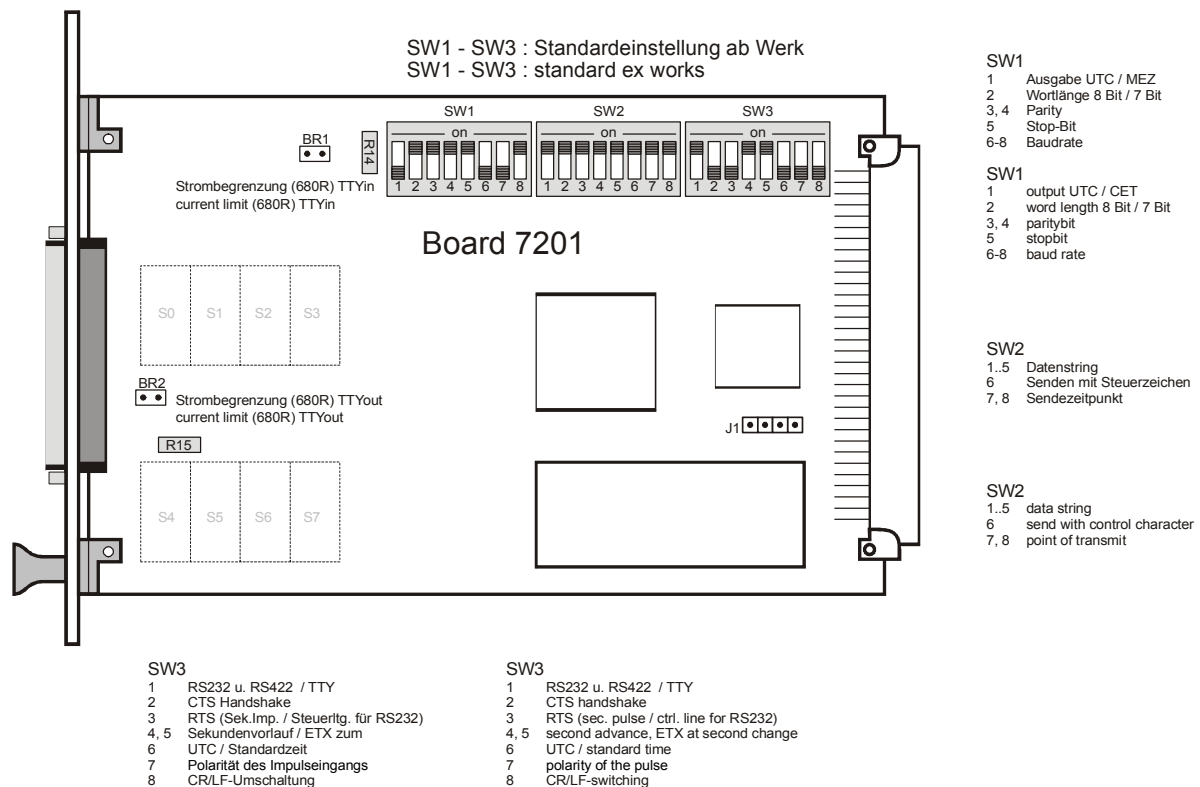

1.1.3 Hardware-configuration - Board 7201

1.1.3.1 Choice of Interface

The radio clock is equipped with 3 serial interfaces:

RS232c (V.24), RS422 (V.11), TTY (20mA-passive)

If a cyclic data output is preset the data string appears at all serial exits. The request for data via the RxD lines can come from only one entry. It is possible to configure the board especially for this case by means of DIP-Switch 3 push button 1 between entry TTY or RS232/RS422.

DIP-Switch 3 push button1

- on** serial input RS232c and RS422 active
- off** serial input TTY active

The RS232- and RS422 interfaces are equipped with a potential separation.

A series resistance (680 Ohm) to limit the current can be looped into the TTY- interface. For this purpose bridge BR1 for the input and BR2 for the output must be opened (see position diagram in the appendix).

1.1.3.2 Handshakelines (only with RS232c)

The RS232c-interface of the board is equipped with the standard handshake lines which can be used or deactivated depending on the use. DIP-Switch 3 push button 2 selects the use.

DIP-Switch 3 push button 2

- on** RTS ⇒ CTS Handshake active
- off** RTS ⇒ CTS Handshake inactive

The RS232 control line RTS can also be used as second pulse. For this purpose the handshake switch must be activated.

DIP-Switch 3 push button 3

- on** RTS as second pulse with RS232c level
- off** RTS as control line for RS232c

<p>Please Note: WHEN OPERATING THE BOARD VIA RS422/TTY-INTERFACE DIP-SWITCH 3 PUSH BUTTON 2 MUST BE IN THE OFF POSITION.</p>

1.1.4 Pin Assignment - Board 7201

1.1.4.1 RS232c-Interface

25-pole Sub-D-connector in the front panel pin no.	Signal name	96-pole VG-strip pin no.:
2	TxD (transmit data)	2a
3	RxD (receive data)	3a
4	RTS (ready to send)	4a
5	CTS (clear to send)	5a
7	0 Volt (GND)	7a

1.1.4.2 TTY-Interface (passive)

25-pole Sub-D-connector in the front panel pin no.	Signal name	96-pole VG-strip pin no.:
7	0 Volt (GND)	7a
9	+ output	9a
10	- output	10a
24	+ input	11c
25	- input	12c

1.1.4.3 RS422-Interface

25-pole Sub-D-connector in the front panel pin no.	Signal name	96-pole VG-strip pin no.:
7	0 V (GND)	7a
11	RS422 (V.11) -TxD ^L	11a
12	RS422 (V.11) +TxD ^H	12a
22	RS422 (V.11) -RxD ^L	9c
23	RS422 (V.11) +RxD ^H	10c

^L RS422 (V.11) low active
^H RS422 (V.11) high active

1.1.5 Technical Data - Board 7201

voltage supply:	+ 5 V DC \pm 5%
current consumption:	approx. 300 mA
interfaces:	TTY-passive / RS232c / RS422
data-format:	ASCII
MTBF:	250 000 h
extras:	Hard- and software alterations according to customer specifications are possible.

Please Note: THE **hopf** COMPANY WITHHOLD THE RIGHT TO HARD- AND SOFTWARE ALTERATIONS AT ANY TIME.

1.1.6 Block Diagram - Board 7201

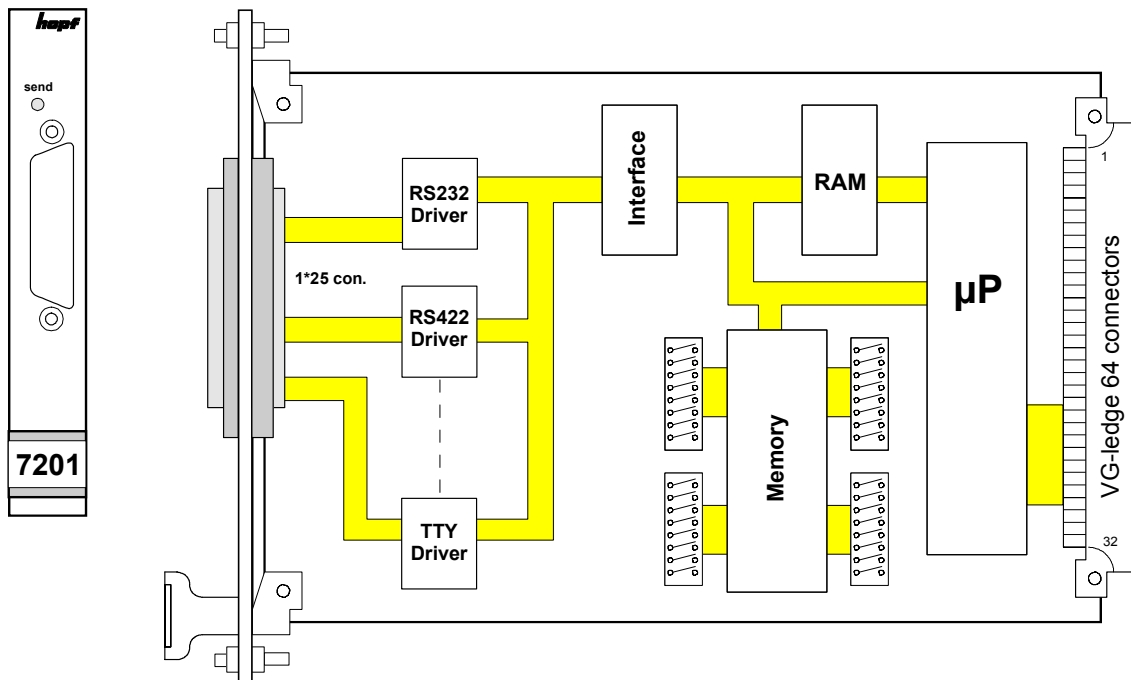

1.2 Interface Board 7221

1.2.1 Functional Description

The microprocessor of the interface board 7221 receives the time information via the **hopf** 7001 system bus.

The received time is put out via 8 interfaces. It is possible to set cyclic data outputs (e.g. every minute data output) by means of a DIP-switch. Baud rate, word length as well as the number of stop bits and parity mode can also be set by means of a DIP-switch.

It is possible to set various data strings as output data strings by means of a DIP-switch.

1.2.2 Specifications

- Data output via: RS232c (V.24), RS422c (V.11)
- Baud rate: 150 - 19200 Baud
- Various output strings can be set by DIP-switch (e.g. output of UTC-time)
- Indication of internal clock status in the status byte of the data string.
- Two potential separate RS232- and RS422 interfaces (S0 and S7).

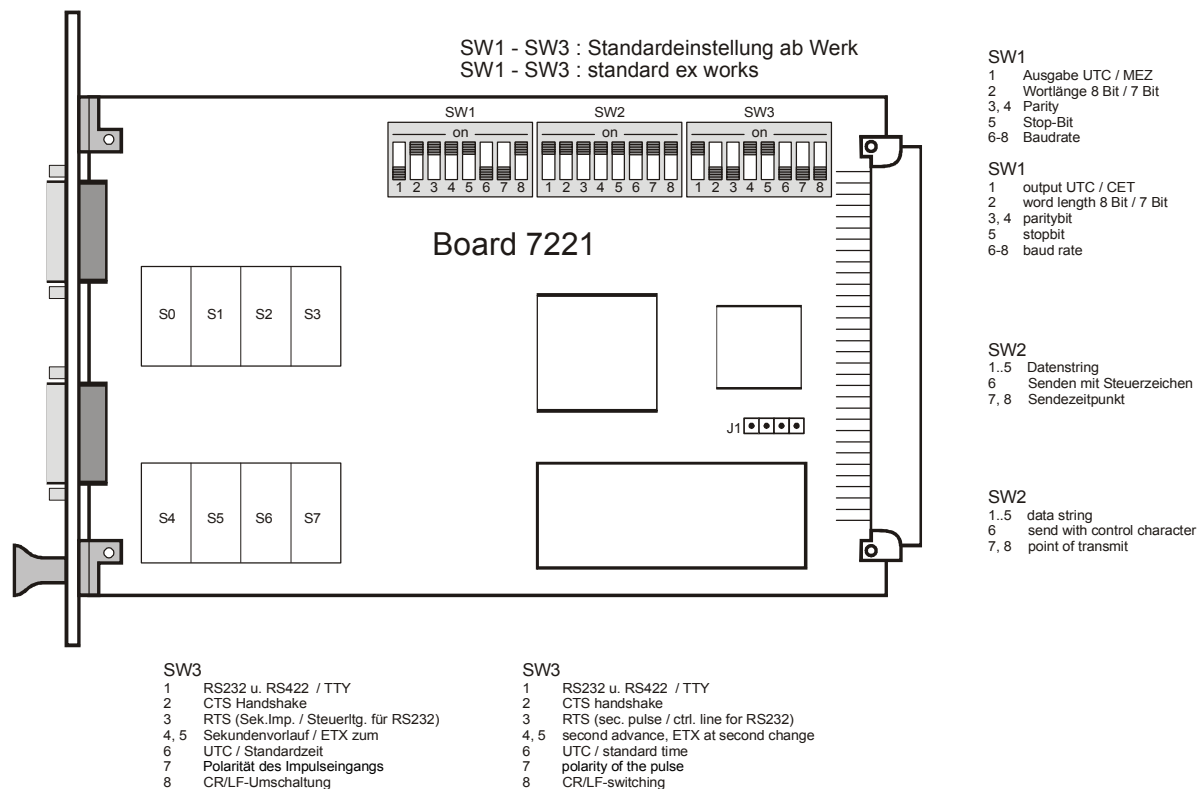

1.2.3 Hardware-configuration - Board 7221

1.2.3.1 Choice of Interface

The radio clock is equipped with 8 serial interfaces. Every interface connector (S0-S7) has the standard interface formats:

RS232c (V.24), RS422 (V.11)

The RS232- and RS422 interfaces of S0 and S7 are equipped with potential separation. S0 can also operate with the handshake lines RTS/CTS.

The interface S0 has a serial input where time data can be requested using ASCII control characters. Optionally it is possible to equip the interface S7 with a serial input at a later date.

S1-S6/7 can be used only as outputs. When the cyclic output is set the data string appears at all the serial outputs (S0-S7). Data request via the RxD line at interface S0 may be carried out only via RS232 or RS422.

1.2.3.2 Handshakelines (only at RS232c and S0)

The RS232c-interface of the interface S0 is equipped with the standard handshake lines. These handshake lines can be - depending on the purpose - either used or deactivated. Selection by DIP-Switch 3 switch 2.

DIP-Switch 3 switch 2

- on** RTS ⇔ CTS handshake active
- off** RTS ⇔ CTS handshake inactive)

The RS232 control line RTS can also be used as second pulse. To do so **DIP-Switch 3 switch 2 must be on** (handshake-switch inactive).

DIP-Switch 3 switch 3

- on** RTS as second pulse with RS232 level
- off** RTS as control line for RS232

<p>Please Note: WHEN OPERATING THE BOARD AT THE INTERFACES S1-S7 DIP-SWITCH 3 SWITCH 2 MUST BE IN POSITION OFF.</p>

1.2.4 Pin Assignment - Board 7221

1.2.4.1 The Interface S0

The interface S0 is also connected to the VG-strip. The assignment is listed below:

9-pole SUB-D connector in the front panel pin no.	signal name	96-pole VG-strip pin no.:
1	GND	7 a
2	RxD (receive data) RS232c	3 a
3	CTS (clear to sent) RS232c	5 a
4	I + (input) RS422	9 c
5	I + (output) RS422	11 a
6	TxD (transmit data) RS232c	2 a
7	RTS (ready to sent) RS32c	4 a
8	I - (input) RS422	10 c
9	I - (output) RS422	12 a

1.2.4.2 The Interfaces S1-S7

9-pole SUB-D connector in the front panel pin no.	signal name
1	GND
5	I + (output) RS422
6	TxD (transmit data) RS232c
9	I - (output) RS422

1.2.5 Technical Data - Board 7221

voltage supply:	+ 5 V DC \pm 5%
current consumption:	approx. 450 mA
interfaces:	RS232c / RS422
data-format:	ASCII
MTBF:	200 000 h
extras:	Hard- and software alterations according to customer specifications are possible.

Please Note: THE **hopf** COMPANY WITHHOLD THE RIGHT TO HARD- AND SOFTWARE ALTERATIONS AT ANY TIME.

1.2.6 Block Diagram - Board 7221

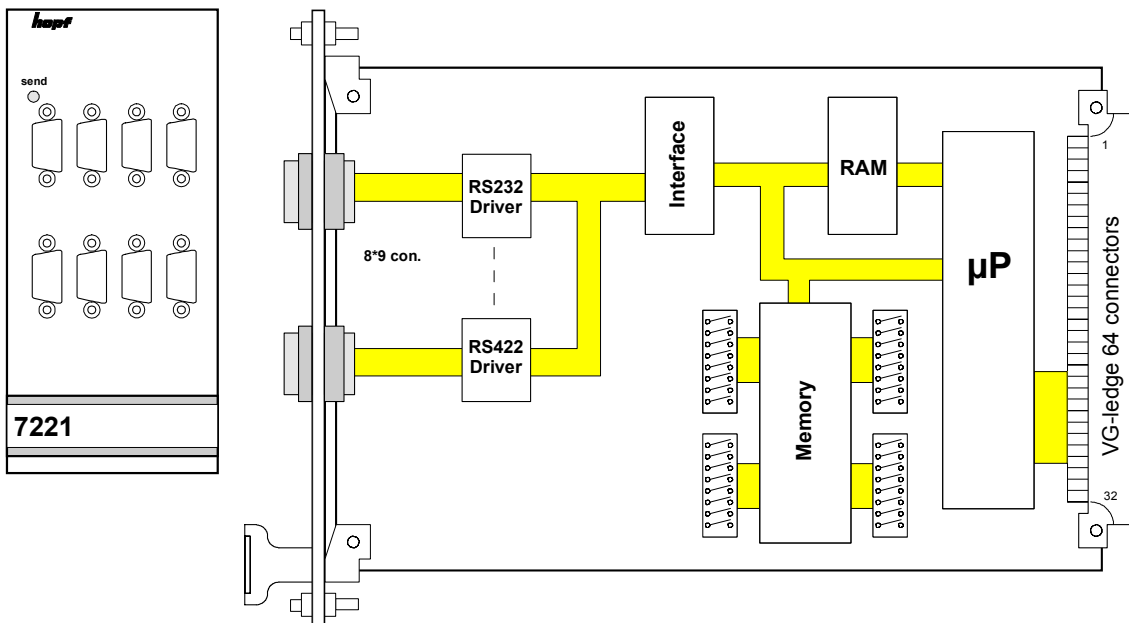

2 The transmitted Data Strings

The received time can be transmitted in a data string via the interfaces stating the internal clock-status, which enables the user to synchronise the connected computer with the atom-precise time. DIP-switch SW2 can be used to choose the desired output point of time, the string structure and the used control characters.

Possible settings by means of DIP-switch SW2

SW2 -1	SW2 -2	SW2 -3	SW2 -4	SW2 -5	data string output	
on	on	on	on	*	6021 (standard)	Standard
on	on	on	off	*	5500	
on	on	off	on	*	5050	
on	on	off	off	*	2000	
on	off	on	on	on	date / time	
on	off	on	on	off	SINEC H1 Extended	
on	off	on	off	on	MADAM S	
on	off	on	off	off	SINEC H1	
on	off	off	on	on	DCF-Slave	
on	off	off	on	off	T-string	
on	off	off	off	on	UTC-Slave	
on	off	off	off	off	IBM Sysplex Timer 1+2	
off	on	on	on	on	Sicomp M	
off	on	on	on	off	H&B	
off	on	on	off	on	Master/Slave-String	
off	on	on	off	off	ABB 23RC20 protocol	
off	on	off	on	on	ABB-SPA	
off	on	off	on	off	data string with microsecond	
off	on	off	off	on	MDR 2000	
off	on	off	off	off	Clock-mouse	
off	off	on	on	on	Clock-mouse with <o><CR>	
off	off	on	on	off	DCF77-pulse output	
off	off	on	off	on	NMEA - GPRMC	
off	off	on	off	off	DA55	
off	off	off	on	on	OMS Synchro	
off	off	off	on	off	CCTV	
off	off	off	off	on	ABB Master Clock	
off	off	off	off	off	IRIG J1x	

* SW2 Pos 5: on = date and time / off = time only

Please Note: WHEN THE PULSE OUTPUT DCF77 IS SET THE SWITCHES **Pos 6-8** IN **DIP-SWITCH 2** HAVE A DIFFERENT MEANING (SEE 3.23.1)

SW2 pos. 6	control character STX/ETX	
on	transmission with control characters	Standard
off	transmission without control characters	

SW2 pos. 7	SW2 pos. 8	transmission point of time	
on	on	transmission every second	Standard
on	off	transmission on the minute change	
off	on	transmission on the hour change	
off	off	transmission on request	

Set-up with DIP-Switch SW3

pos. 4	pos. 5	advance	ETX	transmission delay	
on	on	Off	immediately	off	Standard
on	off	On	immediately	off	
off	on	On	on sec.-change	off	
off	off	On	on sec.-change	on	

2.1 Data Format of the Serial Transmission

The data are transmitted in the ASCII format as BCD values using the following special characters:

- \$20 = Space
- \$0D = CR (carriage return)
- \$0A = LF (line feed)
- \$02 = STX (start of text)
- \$03 = ETX (end of text)

Please Note: IN CASE OF ALL, EXCEPT FOR THE "SLAVE DATA STRINGS", THE OUTPUT OF THE CONTROL CHARACTERS CR AND LF CAN BE EXCHANGED BY MEANS OF DIP-SWITCH 3 SWITCH 8 = ON.

2.2 Serial Request

The user can start the data string output using control characters. These control characters are:

- ASCII **"U"** -- for time
- ASCII **"D"** -- for time/date
- ASCII **"G"** -- for UTC-time/date

The system answers within 1 msec. with the according data string.

This is often too fast for the requesting computer. It is therefore possible to delay the answer in 10 msec. steps on request of the necessary software. To delay the transmission of the data string the small letters "u, d, g" are transmitted to the clock by the requesting computer with a two digit multiplication factor.

The multiplication factor is interpreted by the clock as hexadecimal values.

Example:

The computer sends **ASCII u05** (Hex 75, 30, 35)
The clock answers with the data string time only after 50 milliseconds

The computer sends **ASCII gFF** (Hex 67, 46, 46)
The clock sends the data string UTC time/date after 2550 milliseconds

In case of the set output "MADAM-S compatible" the output can be activated only by the following character sequences

:ZSYS:
or :WILA:

The system answers here on the next second change.

In case of the set output "Sysplex Timer" the output can be activated only by ASCII **"C"**.

2.3 Selection of the Transmission Format by means of DIP-switch SW1

DIP-switch SW1 is used to set the baud rate, the word length, parity-mode and the stop-bits for the data transfer. The selected configuration applies to all 3 existing interfaces.

The different settings of the Dip-switches you can see in the location plan.

2.3.1 Output Local Time, Standard Time or UTC

The time basis for the output string can be selected by means of switch 1 / SW1 and switch 6 / SW3. Normally the local time is selected as time basis. But this time changes by one hour if changeovers from winter to summer time were programmed on the location. If time leaps are to be avoided standard time or UTC should be selected as time basis.

The standard time differs from the local summer time by minus 1 hour. The time progresses continuously through the year. In case of the setting UTC the global time (previously GMT) is used as time basis, which also progresses continuously through the year. Depending on the place of installation the time difference may vary by ± 12 hours.

switch 1	time	meaning	
on	UTC	SW3 / switch 6 = off	
on	standard	SW3 / switch 6 = on	
off	local		Standard

2.3.2 Setting the Word Length

switch 2	meaning	
on	8 data bit	Standard
off	7 data bit	

2.3.3 Setting the Parity-Mode of the Transmission

switch 3	switch 4	meaning	
on	on	no parity bit	Standard
on	off	no parity bit	
off	on	parity even	
off	off	parity odd	

2.3.4 Setting the Stop Bits

switch 5	meaning	
on	1 stop bit	Standard
off	2 stop bit	

2.3.5 Setting the Baud rate

switch 6	switch 7	switch 8	baud rate	
on	on	on	150 baud	
on	on	off	300 baud	
on	off	on	600 baud	
on	off	off	1200 baud	
off	on	on	2400 baud	
off	on	off	4800 baud	
off	off	on	9600 baud	Standard
off	off	off	19200 baud	

3 The different Data Strings

3.1 Data String 7001/6021

3.1.1 Data String 7001/6021 time and date (standard)

The control characters STX and ETX cannot be transmitted unless the output has been set "with control characters" at DIP-switch 2 (DIP-switch 2 switch 6 = on). Otherwise these control characters are left out. The setting "ETX delayed" transmits the last character (ETX) exactly on the next second change.

<u>character no.</u>	<u>meaning</u>
1	STX (start of text)
2	status (internal clock status) ; see 3.1.3
3	day of the week (1=Monday ... 7=Sunday) ; see 3.1.3 for UTC time bit 3 is set to 1 in the day of the week
4	hour tens digit
5	hour unit digit
6	minute tens digit
7	minute unit digit
8	second tens digit
9	second unit digit
10	day tens digit
11	day unit digit
12	month tens digit
13	month unit digit
14	year tens digit
15	year unit digit
16	LF (line feed)
17	CR (carriage return)
18	ETX (end of text)

3.1.2 Data String 7001/6021 time only

The control characters STX and ETX cannot be transmitted unless the output has been set "with control characters" at DIP-switch 2 (DIP-switch 2 switch 6 = on). Otherwise these control characters are left out. The setting "ETX delayed" transmits the last character (ETX) exactly on the next second change.

<u>character no.</u>	<u>meaning</u>
1	STX (start of text)
2	hour tens digit
3	hour unit digit
4	minute tens digit
5	minute unit digit
6	second tens digit
7	second unit digit
8	LF (line feed)
9	CR (carriage return)
10	ETX (end of text)

3.1.3 Data String 7001/6021 Status and Day of the Week Nibble

The second and the third ASCII-character contain the status and the day of the week. The status is decoded binarily Structure of these characters :

	b3	b2	b1	b0	meaning
status nibble:	x	x	x	0	no announcement hour
	x	x	x	1	announcement(ST-WT-ST)
	x	x	0	x	standard time (WT)
	x	x	1	x	daylight saving time (ST)
	0	0	x	x	time / date invalid
	0	1	x	x	crystal operation
	1	0	x	x	radio operation
	1	1	x	x	radio operation (high accuracy)
day of the week nibble:	0	x	x	x	CEST / CET
	1	x	x	x	UTC - time
	x	0	0	1	Monday
	x	0	1	0	Tuesday
	x	0	1	1	Wednesday
	x	1	0	0	Thursday
	x	1	0	1	Friday
	x	1	1	0	Saturday
	x	1	1	1	Sunday

3.1.4 Example of transmitted Data String 7001/6021

(STX)E3123456030196(LF)(CR)(ETX)

radio operation (high accuracy)
 daylight saving time, no announcement
 It is Wednesday 03.01.96 - 12:34:56 h.
 () - ASCII-control characters e.g. (STX)

3.2 Data String 5500

3.2.1 Data String 5500 Time and Date

The control characters STX and ETX cannot be transmitted unless the output has been set "with control characters" at DIP-switch 2 (DIP-switch 2 switch 6 = on). Otherwise these control characters are left out. The setting "ETX delayed" transmits the last character (ETX) exactly on the next second change.

<u>character no.</u>	<u>meaning</u>	
1	STX (start of text)	
2	status (internal clock status)	; see 3.2.3
3	space	
4	hour tens digit	
5	hour unit digit	
6	minute tens digit	
7	minute unit digit	
8	second tens digit	
9	second unit digit	
10	space	
11	day tens digit	
12	day unit digit	
13	month tens digit	
14	month unit digit	
15	year tens digit	
16	year unit digit	
17	space	
18	day of the week	; see 3.2.3
19	CR (carriage return)	
20	LF (line feed)	
21	ETX (end of text)	

3.2.2 Data String 5500 Time only

The control characters STX and ETX cannot be transmitted unless the output has been set "with control characters" at DIP-switch 2 (DIP-switch 2 switch 6 = on). Otherwise these control characters are left out. The setting "ETX delayed" transmits the last character (ETX) exactly on the next second change.

<u>character no.</u>	<u>meaning</u>
1	STX (start of text)
2	hour tens digit
3	hour unit digit
4	minute tens digit
5	minute unit digit
6	second tens digit
7	second unit digit
8	CR (carriage return)
9	LF (line feed)
10	ETX (end of text)

3.2.3 Data String 5500 Status and Day of the Week Nibble

	b3	b2	b1	b0	meaning
status nibble:	x	x	x	0	radio operation
	x	x	x	1	crystal operation
	x	x	0	x	no announcement WT-ST-WT
	x	x	1	x	announcement WT-ST-WT
	x	0	x	x	standard time
	x	1	x	x	daylight saving time
	1	0	0	x	UTC
day of the week nibble:	x	0	0	1	Monday
	x	0	1	0	Tuesday
	x	0	1	1	Wednesday
	x	1	0	0	Thursday
	x	1	0	1	Friday
	x	1	1	0	Saturday
	x	1	1	1	Sunday

3.2.4 Example of a transmitted Data String 5500

(STX)1 123456 030196 3(CR)(LF)(ETX)

crystal operation, no announcement, standard time
It is Wednesday 03.01.96 - 12:34:56 h

3.3 Data String 5050

3.3.1 Data String 5050 Time and Date

The control characters STX and ETX cannot be transmitted unless the output has been set "with control characters" at DIP-switch 2 (DIP-switch 2 switch 6 = on). Otherwise these control characters are left out. The setting "ETX delayed" transmits the last character (ETX) exactly on the next second change.

<u>character no.</u>	<u>meaning</u>	
1	STX (start of text)	
2	hour tens digit	
3	hour unit digit	
4	space	
5	minute tens digit	
6	minute unit digit	
7	space	
8	second tens digit	
9	second unit digit	
10	space	
11	day tens digit	
12	day unit digit	
13	space	
14	month tens digit	
15	month unit digit	
16	space	
17	year tens digit	
18	year unit digit	
19	space	
20	status: internal clock status	; see 3.3.3
21	day of the week	; see 3.3.3
22	space	
23	CR (carriage return)	
24	LF (line feed)	
25	ETX (end of text)	

3.3.2 Data String 5050 Time only

<u>character no.</u>	<u>meaning</u>
1	STX (start of text)
2	hour tens digit
3	hour unit digit
4	space
5	minute tens digit
6	minute unit digit
7	space
8	second tens digit
9	second unit digit
10	space
11	CR (carriage return)
12	LF (line feed)
13	ETX (end of text)

3.3.3 Data String 5050 Status and Day of the Week Nibble

	b3	b2	b1	b0	meaning
status nibble:	x	x	x	0	radio operation
	x	x	x	1	crystal operation
	x	x	1	x	announcement (WT - ST - WT)
	x	x	0	x	no announcement (WT - ST - WT)
	x	0	x	x	CET (UTC + 1h)
	x	1	x	x	CEST (UTC + 2h)
	1	0	0	x	UTC
day of the week nibble:	x	0	0	1	Monday
	x	0	1	0	Tuesday
	x	0	1	1	Wednesday
	x	1	0	0	Thursday
	x	1	0	1	Friday
	x	1	1	0	Saturday
	x	1	1	1	Sunday

3.3.4 Example of a transmitted Data String 5050

(STX) 12 34 56 03 01 96 03 (CR)(LF)(ETX)

radio operation, no announcement, standard time
It is Wednesday 03.01.96 - 12:34:56 h

3.4 Data String MADAM-S

The structure depends on the request string. When the superior computer (PROMEA-MX) requests with the string:

:ZSYS:

the clock answers with the following data string:

<u>character no.</u>	<u>meaning</u>	<u>value (value range)</u>
1	STX (start of text)	\$02
2	: colon	\$3A
3	Z ASCII Z	\$5A
4	S ASCII S	\$53
5	Y ASCII Y	\$59
6	S ASCII S	\$53
7	: colon	\$3A
8	status of the changeover	\$00, 01, 7F ; see 3.4.2
9	time scale identification	\$30-33
10	day of the week	\$31-37
11	tens year	\$30-39
12	unit year	\$30-39
13	tens month	\$30-31
14	unit month	\$30-39
15	tens day	\$30-33
16	unit day	\$30-39
17	tens hour	\$30-32
18	unit hour	\$30-39
19	tens minute	\$30-35
20	unit minute	\$30-39
21	tens second	\$30-35
22	unit second	\$30-39
23	CR (carriage return)	\$0D
24	LF (line feed)	\$0A
25	ETX (end of text)	\$03

When the superior computer (PROMEA-MX) requests using the string

:WILA:

the clock answers with the following data string

<u>character no.</u>	<u>meaning</u>	<u>value (value range)</u>
1	STX (start of text)	\$02
2	: colon	\$3A
3	W ASCII W	\$57
4	I ASCII I	\$49
5	L ASCII L	\$4C
6	A ASCII A	\$41
7	: colon	\$3A
8	status	\$00, 01, 7F ; see 3.4.2
9	time scale ident.	\$30-33
10	day of the week	\$31-37
11	tens year	\$30-39
12	unit year	\$30-39
13	tens month	\$30-31
14	unit month	\$30-39
15	tens day	\$30-33
16	unit day	\$30-39
17	tens hour	\$30-32
18	unit hour	\$30-39
19	tens minute	\$30-35
20	unit minute	\$30-39
21	tens second	\$30-35
22	unit second	\$30-39
23	CR (carriage Return)	\$0D
24	LF (line feed)	\$0A
25	ETX (end of text)	\$03

3.4.1 Required setting in case of output MADAM-S

The synchronisation process in case of output MADAM-S requires the following setting on the board:

- output on the minute change
- output with second advance
- output ETX on the second change
- output with control characters
- output CR/LF

3.4.2 Data String MADAM-S Status Nibble

Announcement of a changeover (8. byte of the transmission)

This byte can have the following values

Nul (Hex 00)	no announcement
SOH (Hex 01)	announcement changeover daylight saving time / standard time standard time / daylight saving time
DEL (Hex 7F)	no radio time available

time scale ident. (9. Byte of the transmission)

ASCII 0 (Hex 30)	standard time
ASCII 1 (Hex 31)	daylight saving time + announcement
ASCII 3 (Hex 33)	daylight saving time

The day of the week nibble can have the values

ASCII 1 (Hex 31 ⇔ MO) to ASCII 7 (Hex 37 ⇔ SO)

In case of an invalid time the byte with ASCII 0 (Hex 30) is transmitted.

3.5 Data String SINEC H1

The control characters STX and ETX cannot be transmitted unless the output has been set "with control characters" at DIP-switch 2 (DIP-switch 2 switch 6 = on). Otherwise these control characters are left out. The setting "ETX delayed" transmits the last character (ETX) exactly on the next second change.

<u>character no.</u>	<u>meaning</u>	<u>value (value range)</u>	
1	STX (start of text)	\$02	
2	"D" ASCII D	\$44	
3	":" colon	\$3A	
4	tens day	\$30-33	
5	unit day	\$30-39	
6	"." point	\$2E	
7	tens month	\$30-31	
8	unit month	\$30-39	
9	"." point	\$2E	
10	tens year	\$30-39	
11	unit year	\$30-39	
12	;" semicolon	\$3B	
13	"T" ASCII T	\$54	
14	":" colon	\$3A	
15	day of the week	\$31-37	
16	;" semicolon	\$3B	
17	"U" ASCII U	\$55	
18	":" colon	\$3A	
19	tens hour	\$30-32	
20	unit hour	\$30-39	
21	"." point	\$2E	
22	tens minute	\$30-35	
23	unit minutes	\$30-39	
24	"." point	\$2E	
25	tens second	\$30-36	
26	unit second	\$30-39	
27	;" semicolon	\$3B	
28	"#" or space	\$23 / \$20	; see 3.5.1
29	"*" or space	\$2A / \$20	; see 3.5.1
30	"S" or space	\$53 / \$20	; see 3.5.1
31	"!" or space	\$21 / \$20	; see 3.5.1
32	ETX (end of text)	\$03	

3.5.1 Status in the Data String SINEC H1

The characters 28 - 31 in the data string SINEC H1 tell the synchronisation status of the clock.

The characters mean the following:

character no. 28 = "#"	no radio synchronisation after reset, time invalid
space	radio synchronisation after reset, clock in crystal operation
character no. 29 = "**"	time from internal crystal in the clock
space	time by radio reception
character no. 30 = "S"	daylight saving time
space	standard time
character no. 31 = "!"	announcement of a W/S or S/W changeover
space	no announcement

3.5.2 Example of a transmitted Data String SINEC H1

(STX)D:03.01.96;T:3;U:12.34.56; _ _ _ _ (ETX) (_) = space

radio operation, no announcement, standard time
It is Wednesday 03.01.96 - 12:34:56 h

3.5.3 String request

The data string SINEC H1 can also send by request. The time of output will be set to "send only by request" and the string will be requested with the ASCII character "?".

3.6 Data String DCF-Slave

This data string is used for the synchronisation of **hopf** DCF-Slave systems. It is the same string as the data string 7001/6021, there is only a difference in the status byte.

<u>character no.</u>	<u>meaning</u>	<u>value (value range)</u>
1	STX (start of text)	\$02
2	status	\$30-39, \$41-46 ; see 3.6.1
3	day of the week	\$31-37 ; see 3.6.1
4	tens hour	\$30-32
5	unit hour	\$30-39
6	tens minute	\$30-35
7	unit minute	\$30-39
8	tens second	\$30-36
9	unit second	\$30-39
10	tens day	\$30-33
11	unit day	\$30-39
12	tens month	\$30-31
13	unit month	\$30-39
14	tens year	\$30-39
15	unit year	\$30-39
16	LF (line feed)	\$0A
17	CR (carriage return)	\$0D
18	ETX (end of text)	\$03

3.6.1 Status in the Data String DCF-Slave

	b3	b2	b1	b0	meaning
status nibble:	x	x	x	0	no announcement hour
	x	x	x	1	announcement (ST-WT-ST)
	x	x	0	x	standard time (WT)
	x	x	1	x	daylight saving time (ST)
	x	0	x	x	no announcement second
	x	1	x	x	announcement second
	0	x	x	x	crystal operation
	1	x	x	x	radio operation
day of the week nibble:	0	0	0	1	Monday
	0	0	1	0	Tuesday
	0	0	1	1	Wednesday
	0	1	0	0	Thursday
	0	1	0	1	Friday
	0	1	1	0	Saturday
	0	1	1	1	Sunday

3.6.2 Example of a transmitted Data String DCF-Slave

(STX)83123456030196(LF)(CR)(ETX)

radio operation, no announcement, standard time
It is Wednesday 03.01.96 - 12:34:56 h

3.6.3 Set-up

To synchronise the **hopf** Slave-systems the following setting are kept:

- output every minute
- output second advanced
- ETX at second change; selectable: data string at the beginning or at the end of the 59. second.
- UTC or local time
- word length 8 Bit
- parity no
- baud rate 9600

Use these settings for an optimal regulation of the time base into the slave-systems.

3.7 Data String UTC-Slave

This string is used when **hopf** clock systems are to run completely on UTC time. The difference time is included in the transmission of the string to calculate the local time. If the local time is positive compared to the UTC time the top bit is set into the "tens hour".

e.g. CET + 1 h compared to UTC, the value 81 is transmitted in the hours.

<u>character no.</u>	<u>meaning</u>	<u>value (value range)</u>
1	STX (start of text)	\$02
2	Status	\$30-39, \$41-46 ; see 3.7.1
3	day of the week	\$39, \$41-46 ; see 3.7.1
4	tens hour	\$30-32
5	unit hour	\$30-39
6	tens minute	\$30-35
7	unit minute	\$30-39
8	tens second	\$30-36
9	unit second	\$30-39
10	tens day	\$30-33
11	unit day	\$30-39
12	tens month	\$30-31
13	unit month	\$30-39
14	tens year	\$30-39
15	unit year	\$30-39
16	tens difference hour	\$30,31,38,39
17	unit difference hour	\$30-39
18	tens difference minute	\$30-35
19	unit difference minute	\$30-39
20	LF (line feed)	\$0A
21	CR (carriage return)	\$0D
22	ETX (end of text)	\$03

3.7.1 Status in the Data String UTC-Slave

	b3	b2	b1	b0	meaning
status nibble:	x	x	x	0	no announcement hour
	x	x	x	1	announcement (ST-WT-ST)
	x	x	0	x	standard time (WT)
	x	x	1	x	daylight saving time (ST)
	x	0	x	x	no announcement second
	x	1	x	x	announcement second
	0	x	x	x	crystal operation
	1	x	x	x	radio operation
day of the week nibble:	1	0	0	1	Monday
	1	0	1	0	Tuesday
	1	0	1	1	Wednesday
	1	1	0	0	Thursday
	1	1	0	1	Friday
	1	1	1	0	Saturday
	1	1	1	1	Sunday

3.7.2 Setting

The following settings are kept to synchronise the **hopf** slave-systems:

- output every minute
- output second advance
- ETX on the second change; selectable: data string at the beginning or at the end of the 59. second.
- UTC or local time
- word length 8 bit
- no parity
- baud rate 9600

This setting guarantees the best control of the time base in the slave systems.

3.8 Data String T-String

The T-String will be sent minutely in the sixtieth second to the Slave-clocks. It contains the complete information of a full minute. After sending "LF" the data string will be processed internally and the millisecond counter will be set to "1".

character no.	meaning	value (value range)
1	"T" ASCII T	\$54
2	":" colon	\$3A
3	tens year	\$30-39
4	unit year	\$30-39
5	":" colon	\$3A
6	tens month	\$30-31
7	unit month	\$30-39
8	":" colon	\$3A
9	tens day	\$30-33
10	unit day	\$30-39
11	":" colon	\$3A
12	tens day of the week	\$30
13	unit day of the week	\$31-37
14	":" colon	\$3A
15	tens hour	\$30-32
16	unit hour	\$30-39
17	":" colon	\$3A
18	tens minute	\$30-35
19	unit minute	\$30-39
20	":" colon	\$3A
21	tens second	\$30-36
22	unit second	\$30-39
23	CR (carriage return)	\$0D
24	LF (line feed)	\$0A

3.8.1 Example of a transmitted Data String T-string

T:96:01:03:03:12:34:56(CR)(LF)

It is Wednesday 03.01.96 - 12:34:56 h

3.9 Data String Date / Time

3.9.1 Data String Date / Time - date and time

The control characters STX and ETX cannot be transmitted unless the output has been set "with control characters" at DIP-switch 2 (DIP-switch 2 switch 6 = on). Otherwise these control characters are left out. The setting "ETX delayed" transmits the last character (ETX) exactly on the next second change.

<u>character no.</u>	<u>meaning</u>
1	STX (start of text)
2	year tens digit
3	year unit digit
4	month tens digit
5	month unit digit
6	day tens digit
7	day unit digit
8	hour tens digit
9	hour unit digit
10	minute tens digit
11	minute unit digit
12	second tens digit
13	second unit digit
14	ETX (end of text)

3.9.2 Example of transmitted Data String - date / time

(STX) 960103123456 (ETX)

daylight saving time, no announcement
It is Wednesday 03.01.96 - 12:34:56 h.
() - ASCII-control characters e.g. (STX)

3.10 SINEC H1 Extended

The control characters STX and ETX are transmitted only if the output is set "with control characters". Otherwise there are no control characters. In case of the setting "ETX delayed" the last character (ETX) is transmitted exactly on the next second change.

The data string SINEC H1 can also be transmitted on request (Set-up: "Transmission on Request"). The data string can be requested by "?".

character no.	meaning	value (value range)
1	STX (start of text)	\$02
2	"D" ASCII D	\$44
3	":" colon	\$3A
4	tens day	\$30-33
5	unit day	\$30-39
6	"." point	\$2E
7	tens month	\$30-31
8	unit month	\$30-39
9	"." point	\$2E
10	tens year	\$30-39
11	unit year	\$30-39
12	"," semicolon	\$3B
13	"T" ASCII T	\$54
14	":" colon	\$3A
15	day of the week	\$31-37
16	"," semicolon	\$3B
17	"U" ASCII U	\$55
18	":" colon	\$3A
19	tens hours	\$30-32
20	unit hours	\$30-39
21	"." point	\$2E
22	tens minute	\$30-35
23	unit minute	\$30-39
24	"." point	\$2E
25	tens seconds	\$30-36
26	unit seconds	\$30-39
27	"," semicolon	\$3B
28	"#" or space	\$23 / \$20
29	"*" or space	\$2A / \$20
30	"S", "U" or space	\$53 / \$55 / \$20
31	!", "A" or space	\$21 / \$41 / \$20
32	ETX (end of text)	\$03

3.10.1 Status in the Data String SINEC H1 Extended

The characters 28-31 in the data string SINEC H1 Extended give information about the synchronisation status of the clock.

meaning of the following:

character no.: 28 = "#"	no radio synchronisation after reset, time invalid
space	radio synchronisation after reset, clock at least in crystal operation
character no.: 29 = "*" space	time from the internal crystal time from radio reception
character no.: 30 = "S"	daylight saving time
"U"	UTC (see chapter 2.3.1)
space	standard time
character no.: 31 = "!"	announcement of a W/S or S/W changeover
"A"	announcement of a leap second
space	no announcement

3.10.2 Example of a Transmitted Data String SINEC H1 Extended

(STX)D:03.01.96;T:3;U:12.34.56; _ _ _ _ (ETX) (_) = Space

radio operation, no announcement, standard time

It is Wednesday 03.01.96 - 12:34:56 h

3.11 Data String 2000

3.11.1 Data String 2000 Time and Date with a 4 Digit Year Output

The control characters STX and ETX cannot be transmitted unless the output has been set "with control characters" at DIP-switch 2 (DIP-switch 2 switch 6 = on). Otherwise these control characters are left out. The setting "ETX delayed" transmits the last character (ETX) exactly on the next second change.

<u>character no.</u>	<u>meaning</u>	
1	STX (start of text)	
2	status (internal clock status)	; see 3.11.2
3	day of the week (1=Monday ... 7=Sunday) for UTC time bit 3 is set to 1 in the day of the week	; see 3.11.2
4	hour tens digit	
5	hour unit digit	
6	minute tens digit	
7	minute unit digit	
8	second tens digit	
9	second unit digit	
10	day tens digit	
11	day unit digit	
12	month tens digit	
13	month unit digit	
14	year thousand digit	
15	year hundred digit	
16	year tens digit	
17	year unit digit	
18	LF (line feed)	
19	CR (carriage return)	
20	ETX (end of text)	

3.11.2 Data String 2000 Status and Day of the Week Nibble

The second and the third ASCII-character contain the status and the day of the week. The status is decoded binarily. Structure of these characters :

	b3	b2	b1	b0	meaning
status nibble:	x	x	x	0	no announcement hour
	x	x	x	1	announcement (ST-WT-ST)
	x	x	0	x	standard time (WT)
	x	x	1	x	daylight saving time (ST)
	0	0	x	x	time / date invalid
	0	1	x	x	crystal operation
	1	0	x	x	radio operation
	1	1	x	x	radio operation (high accuracy)
day of the week nibble:	0	x	x	x	CEST / CET
	1	x	x	x	UTC - time
	x	0	0	1	Monday
	x	0	1	0	Tuesday
	x	0	1	1	Wednesday
	x	1	0	0	Thursday
	x	1	0	1	Friday
	x	1	1	0	Saturday
	x	1	1	1	Sunday

3.11.3 Example of transmitted Data String 2000

(STX)E312345603011996(LF)(CR)(ETX)

radio operation (high accuracy)
 daylight saving time, no announcement
 It is Wednesday 03.01.1996 - 12:34:56 h.
 () - ASCII-control characters e.g. (STX)

3.12 Data String Sysplex Timer Model 1+2

This protocol is used for the synchronization of an IBM 9037 Sysplex Timer. The 9037 expects the time at its input every second.

The following settings are required:

- baud rate 9600
- 8 data bit
- parity odd
- 1 stop bit
- sending on request without advance and without control characters

While starting the Sysplex Timer the ASCII-sign "**C**" is sent to the connected radio controlled clock. The listed protocol in the table is automatically given out every second by that.

The setting UTC or local time is optional.

character no.	meaning	value (value range)
1	SOH (start of header)	\$02
2	hundreds current day of the year	\$30-33
3	tens current year	\$30-39
4	unit current year	\$30-39
5	":" colon	\$3A
6	tens hour	\$30-32
7	unit hour	\$30-39
8	":" colon	\$3A
9	tens minute	\$30-35
10	unit minute	\$30-39
11	":" colon	\$3A
12	tens second	\$30-35
13	unit second	\$30-39
14	Quality Identifier	\$20, 41, 42, 43, 58
15	CR (carriage return)	\$0D
16	LF (line feed)	\$0A

3.12.1 Status in the Data String Sysplex Timer Model 1+2

The 14th character informs about the synchronisation status of the clock. Possible values and their meaning are listed below.

"?"	=	question mark	=	no radio controlled time
" "	=	space	=	radio controlled time at hand
"A"	=	Hex 41	=	crystal operation for more than 20 minutes
"B"	=	Hex 42	=	crystal operation for more than 41 minutes
"C"	=	Hex 43	=	crystal operation for more than 416 minutes
"X"	=	Hex 58	=	crystal operation for more than 4160 minutes

3.12.2 Example of a transmitted Data String Sysplex Timer 1+2

(SOH)050:12:34:56 _ (CR) (LF) (_) = Space

radio operation, 12:34:56 h, 50th day of the year

3.13 Data String for use with NTP (Network Time Protocol)

NTP or also xNTP is a batch of programmes to synchronise different computers and operating systems with network support. It is the standard for the Internet Protokoll TCP/IP (RFC-1305). Source code and documentation are available as freeware in the internet under the following address:

<http://www.eecis.udel.edu/~ntp/index.html>

Binaries for the IBM Operating System AIX are available at the **hopf** Internet site:

<http://www.hopf.com>

NTP supports the **hopf** standard protocol described under pt. "**Data string 7001/6021**". The following adjustments must be made on the board 7201:

parameter of transmission:

- baud rate 9600
- 8 data bit
- parity no
- 1 stop bit

mode of transmission:

- Data String 7001/6021
- UTC as time base
- second in advance = on
- control character (STX...ETX) enabled
- with ETX as On Time Mark
- Output time and date
- output every second

3.14 Data String TimeServ for the Operating System Windows NT

The synchronization of a Computer running Windows NT version 3.51 and higher is done with the same string as described under pt. "**Sysplex Timer**".

The Dip-Switch setting on the board 7201 must match the following items:

- telegram Sysplex Timer
- transmission every second
- baud rate 9600
- 8 data bit
- no parity
- 1 stop bit
- without second advance
- transmission without control characters
- output UTC

To install TimeServ on the WinNT-computer you need the program files which can be found on the Microsoft Windows NT Resource Kit CD. The newest version of the program is although available free of charge on the Microsoft Internet site:

<ftp://ftp.microsoft.com/bussys/winnt/winnt-public/reskit/nt40>

A short description how to setup TimeServ for a **hopf** radio clock is available on the **hopf** internet site:

<http://www.hopf.com>

3.15 Data String Sicomp M

The following string is used for the synchronisation of Sicomp M systems. The string is set-up by DIP-Switch 2+3.

The following parameters are chosen for the data transmission:

- baud rate 9600
- 8 data bit
- parity odd
- 1 stop bit
- Output every minute

The control characters STX and ETX are only transmitted, if the output by DIP-switch 2 is set to "with control characters". In the other case these control character are omitted. By the settings "ETX delayed" the last character (ETX) is transmitted exactly on the next second change.

character no.	meaning	value (value range)
1	STX	\$02
2	" : " colon	\$3A
3	" 3 " DCF77-code	\$33
4	" 4 " DCF77-code	\$34
5	" : " colon	\$3A
6	tens year	\$30-39
7	unit year	\$30-39
8	tens month	\$30-31
9	unit month	\$30-39
10	tens day of the week	\$30
11	unit day of the week	\$31-37
12	tens day	\$30-33
13	unit day	\$30-39
14	tens hour	\$30-32
15	unit hour	\$30-39
16	tens minute	\$30-35
17	unit minute	\$30-39
18	tens second	\$30-36
19	unit second	\$30-39
20	status	\$32-35, \$43
21	error status	\$31-39, \$41-46
22	CR (carriage return)	\$0D
23	LF (line feed)	\$0A
24	ETX (end of text)	\$03

3.15.1 Status in the Data String Sicomp M

The status is built up with 4 bits and the following valency:

b3 = 1	Announcement switching second
b2 = 1	standard time (CET)
b1 = 1	daylight saving time (CEST)
b0 = 1	Announcement time zone switch-over

In case of radio reception the error counter is set to 1 and runs max. to F (\$31-39, \$41-46). It indicates the time how long the radio reception has been interrupted.

3.16 Data String H&B

In this data string the time, date and a status byte are transmitted in the following order:

<u>character no.</u>	<u>meaning</u>	
1	tens hour	
2	unit hour	
3	space	
4	tens minute	
5	unit minute	
6	space	
7	tens second	
8	unit second	
9	space	
10	tens day	
11	unit day	
12	space	
13	tens month	
14	unit month	
15	space	
16	tens year	
17	unit year	
18	space	
19	status: internal clock status	; see 3.16.1
20	day of the week	; see 3.16.1
21	CR (carriage return)	
22	LF (line feed)	

Please Note: THE TRANSMISSION TAKES PLACE WITH ONE SECOND ADVANCE. THE LAST CHARACTER "LINE FEED" TAKES PLACE AT THE NEXT SECOND CHANGE AND THE VALUES ARE SET VALID. THE SWITCHES SW3 POS. 4 AND 5 MUST BE SET APPROPRIATE.

3.16.1 Data String H&B Status and Day of the Week Nibble

	b3	b2	b1	b0	meaning
status nibble:	x	x	x	0	radio operation
	x	x	x	1	crystal operation
	x	x	1	x	announcement (ST-WT-ST)
	x	x	0	x	no announcement (ST-WT-ST)
	x	0	x	x	MEZ (UTC + 1h)
	x	1	x	x	MESZ (UTC + 2h)
	1	0	0	x	UTC
day of the week nibble:	x	0	0	1	Monday
	x	0	1	0	Tuesday
	x	0	1	1	Wednesday
	x	1	0	0	Thursday
	x	1	0	1	Friday
	x	1	1	0	Saturday
	x	1	1	1	Sunday

3.16.2 Example of a transmitted Data String H&B

(STX) 12 34 56 03 01 96 03(CR)(LF)

crystal operation, no announcement, standard time
It is Wednesday 03.01.96 - 12:34:56 h.

3.17 Data String Master/Slave

This master /slave string can be used to synchronise slave systems with the time data of the master system up to an accuracy of ± 0.5 msec. It differs from the DCF-slave-string in as much as the UTC time is included in the transmission.

The difference time is transmitted in hours and minutes following the year. The transmission is done in BCD. The difference time may be up to ± 11.59 h.

The sign is shown as the highest bit in the hours.

logic "1" = local time before UTC

logic "0" = local time after UTC

Example :

90.00 difference time + 10.00 h.

01.30 difference time – 01.30 h.

The whole data string shows the following structure:

character no.	meaning	value (value range)
1	STX (start of text)	\$02
2	status	\$30-39,\$41-46 ;see 3.17.1
3	day of the week	\$31-37 ;see 3.17.1
4	tens hour	\$30-32
5	unit hour	\$30-39
6	tens minute	\$30-35
7	unit minute	\$30-39
8	tens second	\$30-36
9	unit second	\$30-39
10	tens day	\$30-33
11	unit day	\$30-39
12	tens month	\$30-31
13	unit month	\$30-39
14	tens year	\$30-39
15	unit year	\$30-39
16	tens diff.time a. sign hour	\$30-31,\$38-39
17	unit diff.time a. sign hour	\$30-39
18	tens diff. time minutes	\$30-35
19	unit diff. time minutes	\$30-39
20	LF (line feed)	\$0A
21	CR (carriage Return)	\$0D
22	ETX (end of text)	\$03

3.17.1 Status in the Data String Master-Slave

	b3	b2	b1	b0	meaning
status nibble:	x	x	x	0	no announcement hour
	x	x	x	1	announcement (ST-WT-ST)
	x	x	0	x	standard time (WT)
	x	x	1	x	daylight saving time(ST)
	x	0	x	x	no announcement leap second
	x	1	x	x	announcement leap second
	0	x	x	x	crystal operation
	1	x	x	x	radio operation
day of the week nibble	0	0	0	1	Monday
	0	0	1	0	Tuesday
	0	0	1	1	Wednesday
	0	1	0	0	Thursday
	0	1	0	1	Friday
	0	1	1	0	Saturday
	0	1	1	1	Sunday

3.17.2 Example of a Transmitted Data String Master-Slave

(STX)831234560301968230(LF)(CR)(ETX)

Radio operation, no announcement, standard time

It is Wednesday 03.01.96 - 12:34:56 h

The difference to UTC is +2.30 hours

3.17.3 Settings

The following settings are required for the synchronisation of the **hopf** slave-systems :

- output every minute
- output second advance
- ETX on the second change; selectable: data string at the beginning or at the end of the 59. second.
- 9600 baud, 8 bit, 1 stop bit, no parity

This setting guarantees the best control of the time basis in the slave systems.

Please Note: IN CASE OF MASTER/SLAVE-STRING THESE SETTINGS ARE FIXED INDEPENDENTLY OF THE ACTUAL DIP-SWITCH SETTINGS.

3.18 Data String with Microsecond

The output of the data string can only be activated via the pulse input of the 25-pole SUB-D connector. For this either the 5 or the 24 Volt input must be connected to a suitable source of signal. The polarity of the pulse input can be selected by the DIP switch 3 switch 7.

DIP switch block 3

switch 7	meaning
on	falling edge releases measuring
off	rising edge releases measuring

Please Note: IF THE DATA STRING IS SET WITH MICROSECOND THE PULSE INPUT MUST BE WIRED-UP. OTHERWISE THERE MAY BE MALFUNCTIONS IN THE DATA OUTPUT (OPEN INPUT).

wiring of the pulse input	
pin 16	+ 24 Volt
pin 17	GND
pin 18	+ 5 Volt

A signal edge at the input releases an intermediate measuring of time. Up to 20 measurings at short intervals (200 µsec) are possible. The values are stored in a FIFO memory precisely to the microsecond and putout in consecutive order on the serial data line. If the memory is full the subsequent measurings are ignored until the present data are putout via the serial interface.

The accuracy of the measuring depends on the synchronisation status of the clock system. To avoid faulty measurings they should not be carried out during synchronisation (see pt. synchronisation of the clock system 7001 - status byte of the output data string)

The data are putout in the following string:

character no.:	meaning	value (value range)
1	STX (start of text)	\$02
2	status	\$30-39, \$41-46 ; see 3.1.3
3	day of the week	\$31-37 ; see 3.1.3
4	" " space	\$20
5	tens hour	\$30-32
6	unit hour	\$30-39
7	":" colon	\$3A
8	tens minute	\$30-35
9	unit minute	\$30-39
10	":" colon	\$3A
11	tens second	\$30-35
12	unit second	\$30-39
13	":" colon	\$3A
14	hundred digit millisecond	\$30-39
15	tens millisecond	\$30-39
16	unit millisecond	\$30-39
17	"." point	\$2E
18	hundred digit microsecond	\$30-39
19	tens microsecond	\$30-39
20	unit microsecond	\$30-39
21	"." point	\$2E
22	tens day	\$30-33
23	unit day	\$30-39
24	"." point	\$2E
25	tens month	\$30-31
26	unit month	\$30-39
27	"." point	\$2E
28	thousand digit year	\$31, \$32
29	hundred digit year	\$30, \$39
30	tens year	\$30-39
31	unit year	\$30-39
32	LF (line feed)	\$0A
33	CR (carriage return)	\$0D
34	ETX (end of text)	\$03

3.19 Data String 23RC20

This data string is pre-set as follows:

- 8 data bit
- parity even
- 1 stop bit

The baud rate should be 2400 baud but a different rate can be selected.

The data string is started 2 seconds after every minute change. The content of the data string is the time on the next minute change. The data are put out coded binarily.

The complete data string has the following structure:

character no.:	meaning	value (value range)
1	status	\$00-FF
2	second	\$00
3	minute	\$00-3B
4	hour	\$00-17
5	day	\$01-1F
6	month	\$01-0C
7	year	\$00-63

3.19.1 Status in the Data String 23RC20

Bit	meaning
Bit 0 = 1	synchronous with Mainflingen
Bit 1 = 1	not synchronous with Mainflingen
Bit 2 = 1	no reception for more than 5 minutes, but less than 2.5h
Bit 3 = 1	no reception for more than 2.5h
Bit 4 =	no meaning
Bit 5 = 1	announcement daylight saving / standard time or standard / daylight saving time on the next hour change
Bit 6 = 1	daylight saving time (=0: standard time)
Bit 7 =	no meaning

3.20 Data String ABB-SPA Seconds-Clock

The date and time data string fades over the seconds data string when the output time is the same. In case of the setting "without checksum" the ASCII characters for XX are transmitted instead of the checksum. The putout milliseconds state the (calculated) transmission time of the last character of the string.

Altered Function of the Dip-switch SW3:

SW3 switch 3	separator
off	dot between day and hour
on	space between day and hour

SW3 switch 4	checksum
off	with checksum
on	no checksum (XX)

SW3 switch 5	SW3 switch 6	output point of time/date string
off	off	6 and 18 o'clock
off	on	every hour
on	off	every 30 minutes
on	on	every minute

SW3 switch 7	SW3 switch 8	output point of seconds string
off	off	every minute
off	on	every 30 seconds
on	off	every 10 seconds
on	on	every second

Please Note: ONLY THE OUTPUT OF THE LOCAL TIME OR UTC TIME IS POSSIBLE IN THE DATA STRING ABB-SPA. THE OUTPUT OF LOCAL STANDARD TIME IS NOT POSSIBLE.

Altered Function of the Dip-switch SW1:

SW1 switch 1	time output
off	local time
on	UTC

3.20.1 Seconds String

character no.:	meaning	value (value range)
1	ASCII-character >	\$3E
2	ASCII-character 9	\$39
3	ASCII-character 0	\$30
4	ASCII-character 0	\$30
5	ASCII-character W	\$57
6	ASCII-character T	\$54
7	ASCII-character :	\$3A
8	tens second	\$30-36
9	unit second	\$30-39

10	ASCII-character .	\$2E
11	1/10 second	\$30-39
12	1/100 second	\$30-39
13	1/1000 second	\$30-39
14	ASCII-character :	\$3A
15	checksum H-nibble	\$30-3F, \$58
16	checksum L-nibble	\$30-3F, \$58
17	CR (carriage return)	\$0D

3.20.2 Time Data String Date and Time

<u>character no.:</u>	<u>meaning</u>	<u>value (value range)</u>
1	ASCII-character >	\$3E
2	ASCII-character 9	\$39
3	ASCII-character 0	\$30
4	ASCII-character 0	\$30
5	ASCII-character W	\$57
6	ASCII-character D	\$54
7	ASCII-character :	\$3A
8	tens year	\$30-39
9	unit year	\$30-39
10	ASCII-character -	\$2D
11	tens month	\$30-31
12	unit month	\$30-39
13	ASCII-character -	\$2D
14	tens day	\$30-33
15	unit day	\$30-39
16	ASCII-character .	\$2E
17	tens hour	\$30-32
18	unit hour	\$30-39
19	ASCII-character .	\$2E
20	tens minute	\$30-35
21	unit minute	\$30-39
22	ASCII-character ;	\$3B
23	tens second	\$30-36
24	unit second	\$30-39
25	ASCII-character .	\$2E
26	1/10 second	\$30-39
27	1/100 second	\$30-39
28	1/1000 second	\$30-39
29	ASCII-character :	\$3A
30	checksum H-nibble	\$30-3F, \$58
31	checksum L-nibble	\$30-3F, \$58
32	CR (carriage return)	\$0D

3.21 MDR 2000

This data string serves to synchronise the Atis tape recorders MDR 2000 and MDD500.

The parameter for the serial interface must be set as follows:

- baud rate: 9600 Baud
- data format: 7 Bit
- 2 stop bits
- parity: even
- handshake: no
- control characters: yes
- sequence for CR / LF: SW3 switch 8 off
- synchronisation: every minute, local time, without time advance, output immediately

Please Note: SW3 SWITCHES 4 AND 5 ARE EXCLUDED. DELAY OF TRANSMISSION AND ADVANCE CANNOT BE ALTERED.

The data string is structured as follows:

<u>character no.:</u>	<u>meaning</u>	<u>value (value range)</u>
1	ADR. Recorder transmission head	\$7F
2	0 _____ " _____	\$30
3	0 _____ " _____	\$30
4	S _____ " _____	\$53
5	A _____ " _____	\$41
6	status	\$30-39, 41-46
7	tens year	\$30-39
8	unit year	\$30-39
9	tens month	\$30-31
10	unit month	\$30-39
11	tens day	\$30-33
12	unit day	\$30-39
13	tens hour	\$30-32
14	unit hour	\$30-39
15	tens minute	\$30-35
16	unit minute	\$30-39
17	tens second	\$30-36
18	unit second	\$30-39
19	day of the week	\$31-37
20	checksum H-Nibble	\$30-39, 41-46
21	checksum L-Nibble	\$30-39, 41-46
22	reception address	\$7F
23	CR (carriage return)	\$0D

A checksum controls the transmitted data string. It is made up by adding all the transmitted ASCII characters from 1-20. The low byte of the sum is transmitted (modulo 256).

3.21.1 Status in the Data String MDR 2000

The status contains the following information

	b3	b2	b1	b0	meaning
status nibble:	x	x	x	0	no announcement hour
	x	x	x	1	announcement (ST-WT-ST)
	x	x	0	x	standard time(WT)
	x	x	1	x	daylight saving time (ST)
	0	0	x	x	time/date invalid
	0	1	x	x	crystal operation
	1	0	x	x	radio operation
	1	1	x	x	radio operation (high accuracy)

3.22 Clock-mouse Data String

This data string can be used when the driver software for the clock-mouse is installed. Windows 3.x and Windows 95 computers can be synchronised by means of this software.

The parameter for the serial interface must be set as follows:

- baud rate: 300 Baud
- data format: 7 Bit
- 2 stop bits
- parity: even
- handshake: no
- control characters : yes
- sequence for CR / LF: SW3 switch 8 off
- synchronisation: on request, local time, without advance, output immediately

The data string is structured as follows:

<u>character no:</u>	<u>meaning</u>
1	tens hour
2	unit hour
3	tens minutes
4	unit minutes
5	tens seconds
6	unit seconds
7	day of the week
8	tens day
9	unit day
10	tens month
11	unit month
12	tens year
13	unit year
14	status 1
15	status 2
16	CR (carriage return)

The data string is requested cyclically by the driver software.

3.22.1 Status in the Data String Clock-mouse

The status information consists of 4bit each, meaning the following

Status 1

B3	meaning	
1	announcement of leap second	
B2	B1	meaning
1	0	standard /wintertime
0	1	daylight saving time
B0	meaning	
1	announcement of changeover standard/daylight saving/ standard time	

Status 2

B3	meaning
1	battery voltage too low always 0, because there is no battery
B2	meaning
1	reception interrupted always 0, because reception runs permanently
B1	meaning
1	radio reception
B0	meaning
1	valid time at hand

3.23 Clock-mouse Data String with <o><CR>

This data string has the same structure as the Clock-mouse data string. Merely at the beginning of the string an "o" followed by "CR" is sent. This data string is necessary when a system transmits the string "o<CR>" to the board 7201 and this string is expected back as an echo with a time string.

The parameter for the serial interface must be set as follows:

- baud rate: 300 Baud
- data format: 7 Bit
- 2 stop bits
- parity: even
- handshake: no
- control character: yes
- sequence for CR / LF: SW3 switch 8 off
- synchronisation: on request, local time, without advance, output immediately

Structure of the data string

<u>character no.:</u>	<u>meaning</u>	<u>value (value range)</u>
1	o	\$6F
2	CR (carriage return)	\$0D
3	tens hour	\$30-32
4	unit hour	\$30-39
5	tens minute	\$30-35
6	unit minute	\$30-39
7	tens second	\$30-35
8	unit second	\$30-39
9	day of the week	\$31-37
10	tens day	\$30-33
11	unit day	\$30-39
12	tens month	\$31-32
13	unit month	\$30-39
14	tens year	\$30-39
15	unit year	\$30-39
16	status 1	\$30-39, 41-46
17	status 2	\$30-39, 41-46
18	CR (carriage return)	\$0D

The structure of the status corresponds with the one of the Clock-mouse data string without leading <o><CR> (see 3.22.1).

3.24 DCF77-pulse output

In this setting the DCF77-pulse is put out at the interfaces RS232, RS422 and TTY.

The DCF77-data string puts out the complete time information minute, hour, day of the week and date.

Every second of a minute a particular time information is transmitted, except for the 59th second. The missing signal in this second indicates an imminent minute change in the next second.

At the beginning of every second a pulse is put out for 100 or 200ms. The initial edge of the pulse marks the exact beginning of the second.

The duration of the second markers of 100 and 200 ms (binary 0 and 1) are transformed into a BCD-Code to decode the transmitted data string.

The time data string is divided into 3 different groups, each followed by a parity check:

- P1 = number of minutes
- P2 = number of hours
- P3 = current day of the year , the day of the week and the year

The binary ones of a group are determined and increased to an even number by the parity bit. When a valid time information (CEST) is transmitted the 17th second marker takes 200ms. One hour before the changeovers from CEST to CET or vice versa the 16th second marker takes 200ms.

The coding is shown below:

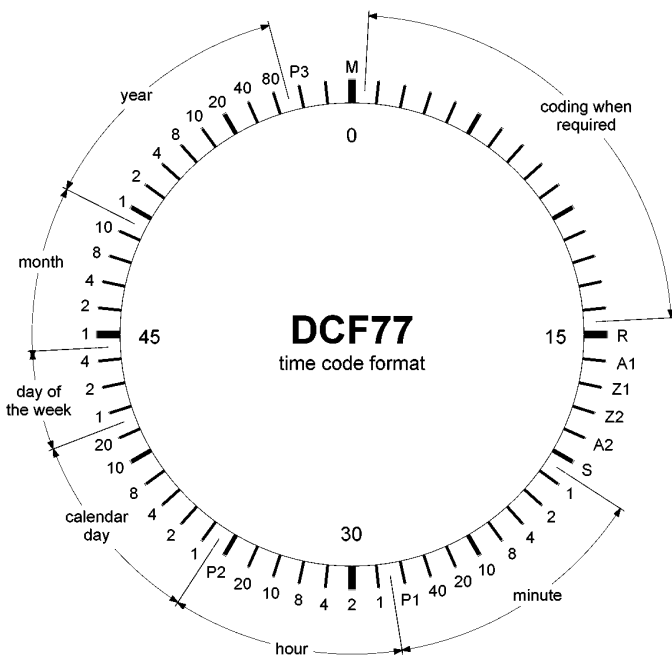

- M** minute marker (0.1 s)
- R** in the simulation this bit is permanently set to logic "0". In the transmitted data string via the DCF77 transmitter this bit becomes logic "1" when a spare antenna is used for the radiation.
- A1** announcement of an imminent changeover from CET to CEST or vice versa.
- Z1, Z2** time zone bits
- A2** announcement of a leap second
- S** initial bit of the coded leap second
- P1, P2, P3** check bits

¹ DCF77 : D = Deutscher
C = Langwellensender
F = Frankfurt
77 = Frequenzhinweis

The following switches on SW2 have changed functions.

Time base

The switch POS 8 is used to select the time base for the structure of the DCF77 data string, the choice being either UTC or local time.

Switch 8	Timebase
off	local time is put out in the DCF77-data string
on	UTC is put out in the DCF77-data string

Output Mode

The switch POS 7 is used to decide if the DCF77 pulse is put out permanently or only if the base system is radio synchronous.

Switch 7	Output Mode
off	output only if the base system is radio synchronous
on	output when the time of the base system is valid

Fault Mode

The DCF77-data string is not put out when the base system does not have a plausible time or if it is not radio synchronous (setting POS 7 – "off").

The output levels of the different interfaces remain in the rest position. This could also simulate a faulty line to the connected device.

POS 6 decides if an un-decodable pulse is putout in case of a fault.

Switch 6	Time Base
off	a constant 2 Hz-pulse is put out in case of a fault
on	the output levels go to rest position in case of a fault

3.25 NMEA Data String GPRMC

The full NMEA data string GPRMC contains the position-, rate- and time data (UTC) calculated by the GPS receiver. The different information are separated in the data string by a comma. Only a comma is set if an information is not available.

The transmitted data string contains only the time information in UTC.

```
$GPRMC, hhmss.ss,A,,,,,,DDMMYY,,*HH<CR><LF>
```

Structure of the data string

character no.:	meaning	value (value range)
1	\$ string start	\$24
2	G	\$47
3	P	\$50
4	R	\$52
5	M	\$4D
6	C	\$43
7	, comma as separation	\$2C
8	tens hour UTC-time	\$30-32
9	unit hour	\$30-39
10	tens minute	\$30-35
11	unit minute	\$30-39
12	tens second	\$30-35
13	unit second	\$30-39
14	. point as separation	\$2E
15	tenth second	\$30-39
16	hundredth second	\$30-39
17	, comma as separation	\$2C
18	A	\$41
19	, comma as separation	\$2C
20	, comma as separation	\$2C
21	, comma as separation	\$2C
22	, comma as separation	\$2C
23	, comma as separation	\$2C
24	, comma as separation	\$2C
25	, comma as separation	\$2C
26	tens day	\$30-33
27	unit day	\$30-39
28	tens month	\$30-31
29	unit month	\$30-39
30	tens year	\$30-39
31	unit year	\$30-39
32	, comma as separation	\$2C
33	, comma as separation	\$2C
34	* string limitation	\$2A
35	tens checksum	\$30-39
36	unit checksum	\$30-39
37	CR (carriage return)	\$0D
38	LF (line feed)	\$0A

The checksum will be calculated from the XOR function of all transmitted ASCII characters between \$... *

All information will be transmitted as ASCII characters with 8 bit word length, 1 stop bit and no parity.

The following settings must be done on the board:

- baud rate = 4800 baud
- word length = 8 bit
- stop bit = 1
- parity = no parity
- transmission point = every second
- forerun off
- ETX immediately
- transmission delay off
- time base = UTC

The following DIP switch setting is necessary:

Pos.	1	2	3	4	5	6	7	8
SW1	off	on	on	on	off	off	on	off
SW2	off	off	on	off	on	on	on	on
SW3	on	off	off	off	off	off	off	off

3.26 DA55 Data String

Structure of the data string

<u>character no.:</u>	<u>meaning</u>	<u>value (value range)</u>
1	tens hour	\$30-32
2	unit hour	\$30-39
3	tens minute	\$30-35
4	unit minute	\$30-39
5	tens second	\$30-35
6	unit second	\$30-39
7	day of the week	\$31-37
8	tens day	\$30-33
9	unit day	\$30-39
10	tens month	\$30-31
11	unit month	\$30-39
12	tens year	\$30-39
13	unit year	\$30-39
14	Status Byte 1	\$30-3F
15	Status Byte 2	\$30-3F
16	CR (carriage return)	\$0D

Status Bytes in Data String DA55

The 14th and 15th ASCII character contain status information. The status is decoded binary.

Structure of these Characters:

The status bytes consist of 7 bits (see settings further down). In Status byte 1 and 2 the status bits **b6**, **b5** and **b4** always have the same value:

- **b6** = 0
- **b5** = 1
- **b4** = 1

That means: 1. Nibble always = 3

Status 1. characters:

B3	meaning	
1	announcement of leap second	
B2	B1	meaning
1	0	standard- or wintertime
0	1	daylight saving time
B0	meaning	
1	announcement of changeover standard- /daylight saving-/standard time	

Status 2. characters:**B3 meaning**

- 1 battery voltage too low, **is always set to 0**
- 0 battery voltage is fine

B2 meaning

- 1 there is no valid time nor reception
- 0 this value is set by the first successful reception

B1 meaning

- 1 clock is radio synchronous
- 0 clock is not radio synchronous

B0 meaning

- 1 there is a valid time
- 0 there is no valid time

All information are transmitted as ASCII characters with 7 bit word length, 2 stop bits and parity bit (even).

The following settings must be done on the board:

- baud rate = 300 baud
- word length = 7 bit
- stop bit = 2
- parity = even parity
- transmission point = every second
- forerun = off
- ETX = immediately
- transmission delay = off
- time base = local

The following dip switch setting is necessary:

Pos.	1	2	3	4	5	6	7	8
SW1	off	off	off	on	off	on	on	off
SW2	off	off	on	off	off	on	on	on
SW3	off	off	off	on	on	off	off	on

When SW2 is set as described above, the settings of SW1 and SW3 are automatically corrected to the described values by internal software filter.

3.27 OMS Synchro Data String

Structure of the data string

<u>character no.:</u>	<u>meaning</u>	<u>value (value range)</u>
1	"\" start character	\$5c
2	"G" source: GPS	\$47
3	tens hour	\$30-32
4	unit hour	\$30-39
5	tens minute	\$30-35
6	unit minute	\$30-39
7	tens second	\$30-35
8	unit second	\$30-39
9	"2" thousands year	\$32
10	"0" hundred year	\$30
11	tens year	\$30-39
12	unit year	\$30-39
13	tens month	\$30-31
14	unit month	\$30-39
15	tens day	\$30-33
16	unit day	\$30-39
17	"0"	\$30
18	unit day of the week	\$30-36 (0=Su, 1=Mo ... 6=Sa)
19	checksum: high nibble	\$30-3F
20	checksum: low nibble	\$30-3F

The following settings must be done on the board:

- baud rate = 9600 Baud
- word length = 8 Bit
- stop bit = 2
- parity = no Parity
- transmission point = every hour
- forerun = off
- transmission delay = off
- time base = UTC / local time

The following dip switch setting is necessary:

Pos.	1	2	3	4	5	6	7	8
SW1	on ¹ off ²	on	on	on	off	off	off	on
SW2	off	off	off	on	on	on	off	on
SW3	on	off	off	off	on	off	off	on

When SW2 is set as described above, the settings of SW1 (without switch 1) and SW3 (without switch 4 [must be off]) are automatically corrected to the described values by internal software filter.

¹ UTC time

² local time

3.28 IRIG J-1x

IRIG J-12..J-18 Data String

- J-12: 300Bd
- J-13: 600Bd
- J-14: 1200Bd
- J-15: 2400Bd
- J-16: 4800Bd
- J-17: 9600Bd
- J-18: 19200Bd

Structure of the Data String

<u>character no.:</u>	<u>meaning</u>	<u>value (value range)</u>
1	SOH	\$01
2	hundred day of the year	\$30-33
3	tens day of the year	\$30-39
4	unit day of the year	\$30-39
5	":" colon	\$3A
6	tens hour	\$30-32
7	unit hour	\$30-39
8	":" colon	\$3A
9	tens minute	\$30-35
10	unit minute	\$30-39
11	":" colon	\$3A
12	tens second	\$30-35
13	unit second	\$30-39
14	Carriage Return	\$0D
15	Line feed	\$0A

3.28.1 Example of a transmitted Data String IRIG J-1x

(SOH)034:12:34:56 (CR)(LF)

It is the 34th day of the year - 12:34:56 o'clock

3.29 CCTV Data String

Structure of the data string

<u>character no.:</u>	<u>meaning</u>	<u>value (value range)</u>
1	"0" start character command	\$30
2	"M" command "Master"	\$4D
3	"a" command end	\$61
4	tens hour	\$30-32
5	unit hour	\$30-39
6	"," comma	\$2C
7	tens minute	\$30-35
8	unit minute	\$30-39
9	"," comma	\$2C
10	tens second	\$30-35
11	unit second	\$30-39
12	"," comma	\$2C
13	"0" start character command	\$30
14	"X" end of string	\$58
15	carriage return	\$0D

The following settings must be done on the board:

- baud rate = 1200 or 4800 Baud
- word length = 8 Bit
- stop bit = 1
- parity = no Parity
- transmission point = every minute
- forerun = off
- transmission delay = off
- time base = UTC / local time

The following dip switch setting is necessary:

Pos.	1	2	3	4	5	6	7	8
SW1	off	on	on	on	on	on ¹ off ²	off ¹ on ²	off
SW2	off	off	off	on	off	on	on	off
SW3	on	off	off	on	on	off	off	off

¹ 1200 Baud

² 4800 Baud

3.30 ABB Master-Clock Data String

Structure of the data string

<u>character no.:</u>	<u>meaning</u>	<u>value (value range)</u>
1	DEL -Character	\$7F
2	"*" asterisk	\$2A
3	"**" asterisk	\$2A
4	"*" asterisk	\$2A
5	tens year	\$30-39
6	unit year	\$30-39
7	":" colon	\$3A
8	tens month	\$30-31
9	unit month	\$30-39
10	":" colon	\$3A
11	tens day	\$30-33
12	unit day	\$30-39
13	":" colon	\$3A
14	tens day of the week	\$30
15	unit day of the week	\$31-37 (1=Mo ... 7=So)
16	":" colon	\$3A
17	tens hour	\$30-32
18	unit hour	\$30-39
19	":" colon	\$3A
20	tens minute	\$30-35
21	unit minute	\$30-39
22	"*" asterisk	\$2A
22	tens second	\$30-35
23	unit second	\$30-39
24	Carriage Return	\$0D
25	Line feed	\$0A
26	DEL -Character	\$7F

The following settings must be done on the board:

- baud rate = 4800 Baud
- word length = 7 Bit
- stop bit = 1
- parity = odd
- transmission point = every minute
- forerun = off
- transmission delay = off
- time base = local time

The following dip switch setting is necessary:

Pos.	1	2	3	4	5	6	7	8
SW1	off	off	off	off	on	off	on	off
SW2	off	off	off	off	on	on	on	off
SW3	on	off	off	on	on	off	off	off