

Industriefunkuhren



Technical Manual

Signal Converter

for DIN Rail Mounting

Series 4800xx-yy

ENGLISH

Version: 01.02 – 07.06.2021

Downloading Technical Manuals

All current manuals of our products are available free of charge via our homepage on the Internet.

Homepage: <http://www.hopf.com>

E-mail: info@hopf.com

Symbols and Characters



Operational Reliability

Disregard may cause damages to persons or material.



Functionality

Disregard may impact function of system/device.



Information

Notes and Information.



Safety regulations

The safety regulations and observance of the technical data serve to ensure trouble-free operation of the device and protection of persons and material. It is therefore of utmost importance to observe and compliance with these regulations.

If these are not complied with, then no claims may be made under the terms of the warranty. No liability will be assumed for any ensuing damage.



Safety of the device

This device has been manufactured in accordance with the latest technological standards and approved safety regulations

The device should only be put into operation by trained and qualified staff. Care must be taken that all cable connections are laid and fixed in position correctly. The device should only be operated with the voltage supply indicated on the identification label.

The device should only be operated by qualified staff or employees who have received specific instruction.

If a device must be opened for repair, this should only be carried out by employees with appropriate qualifications or by **hopf** Elektronik GmbH.

Before a device is opened or a fuse is changed all power supplies must be disconnected.

If there are reasons to believe that the operational safety can no longer be guaranteed the device must be taken out of service and labelled accordingly.

The safety may be impaired when the device does not operate properly or if it is obviously damaged.

CE-Conformity



This device fulfils the requirements of the EU directive 89/336/EWG "Electromagnetic compatibility" and 73/23/EWG "Low voltage equipment".

Therefore the device bears the CE identification marking (CE = Communautés Européennes = European communities)

The CE indicates to the controlling bodies that the product complies with the requirements of the EU directive - especially with regard to protection of health and safety for the operator and the user - and may be released for sale within the common markets.

Contents	Page
1 Signal Converter Series 4800	7
2 Overview and Connections	8
2.1 Converter 4800AC-14 / 4800DC-14 (RS422/RS232 ⇔ Optical Fiber)	8
2.1.1 RS422/RS232 Connection	9
2.1.2 Optical Fiber Connection	9
2.2 Converter 4800AC-04/OC / 4800DC-04/OC (Optical Fiber ⇔ 3x Optocoupler).....	9
2.2.1 Optocoupler Connection	10
2.2.2 Optical Fiber Connection	11
2.3 4800AC-11 / 4800DC-11 (RS422 ⇔ RS232) Converter	11
2.3.1 RS422 Connection	12
2.3.2 RS232 Connection	12
3 Housing Installation	13
3.1 Mounting	13
3.2 Demounting	13
4 Power Supply	14
4.1 Grounding	14
4.2 AC Power Supply – Power Supply Unit AC-M05-D/AC-M10-D	14
4.2.1 Safety and Warning Instructions	14
4.2.2 Power Supply Unit Specifications	15
4.2.3 Power Connection and Control Display	15
4.2.3.1 Connection to various power networks	15
4.2.3.2 Power cable connection.....	15
4.2.3.3 Voltage Input / Fuse Protection.....	16
4.2.3.4 Power LED.....	16
4.3 DC Power Supply – Power Supply Unit DC-M03-D	17
4.3.1 Power Supply Unit Specifications	17
4.3.2 Fuse Protection	17
4.3.3 Polarity Reversal Protection.....	17
4.3.3.1 Power LED.....	17
5 Commissioning	18
5.1 General Procedure	18
5.2 Switch on the Operating Power Supply.....	18

6	Technical Data	19
6.1	General	19
6.2	AC - Power Supply	20
6.3	DC - Power Supply	21
6.4	Optical Fiber Components	21
6.5	RS232/RS422 Signal Inputs/Outputs.....	22
6.6	Optocoupler.....	22
6.7	Dimensions - DIN Rail Housing	23

1 Signal Converter Series 4800

The **hopf** Signal Converter series 4800 for 35mm rail mounting (EN 50 022) is a low cost solution for the active distribution/conversion of a variety of electrical and optical signals.

A choice of either DC or AC power supply units is available for the Signal Converter 4800.

hopf series 4800 Signal Converters with AC power supply have a wide input range in order to render them suitable for worldwide installation. Thus the device can be installed anywhere in the world without being prone to error when switching the AC input voltage range.

Numerous status LEDs for the signal inputs and outputs simplify diagnosis in the event of a fault.

Converters with customer-specific properties can be supplied on request.

Some basic functions of the Signal Converter 4800:

- Robust aluminium housing
- Designed for mounting on 35 mm rails in accordance with EN 50 022
- Each signal input/output has its own status LED
- All connection elements can be interlocked
- Various power supply options are available:
 - AC/DC: 85-264VAC / 100-250VDC (wide input range)
 - DC: 18-72VDC
 - Other voltages on request
- Power supply unit with power LED
- Completely maintenance-free
- Customer-specific converter option

2 Overview and Connections

3 variants are currently available (respectively with AC or DC power supply).

2.1 Converter 4800AC-14 / 4800DC-14 (RS422/RS232 ↔ Optical Fiber)

Device 4800xx-14 is a full duplex optical fiber to RS422/RS232 interface converter.

Housing

Housing type: 1 (**Chapter 6.7 Dimensions - DIN Rail Housing**)

Connection

- The optical fiber transmitter (FL1) and receiver (FL2) are of the ST design.
- The RS232 and RS422 signals are available on the 9-pole SUB-D male connector X1.
- Power input is via the respective connector depending on whether the power supply is AC or DC (see **Chapter 4 Power Supply**).

Status Display

- The optical fiber transmitter and receiver both have a status LED (TxD – yellow and RxD - green) which displays the current operating status of the respective optical fiber component.
- The RS422 and RS232 transmission lines and RS422 and RS232 reception lines each have a common status LED (TxD – yellow and RxD - green) which displays the current operating status of the respective transmission or reception line.

Repeater Function

The optical fiber transmitters and receivers available in the converter can be connected to an optical fiber repeater by means of a connector on the RS422 interface.

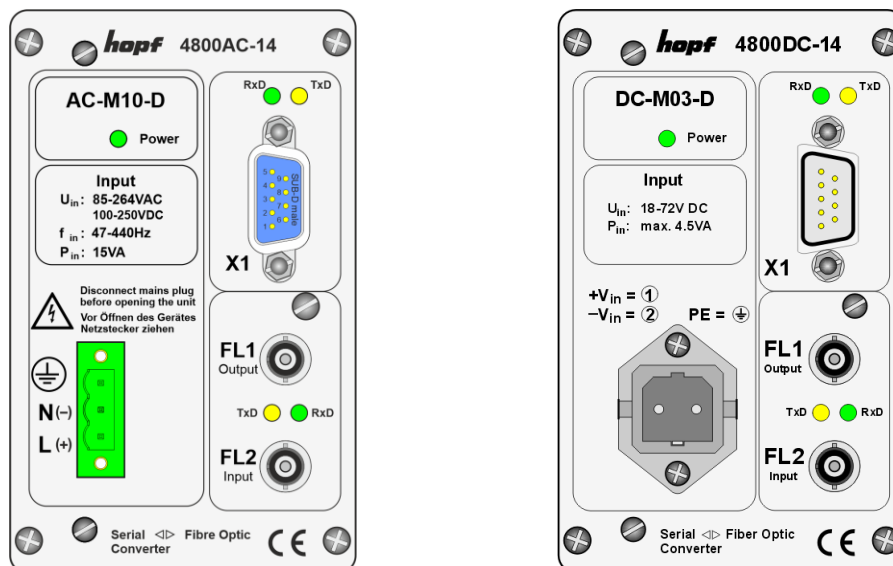

2.1.1 RS422/RS232 Connection

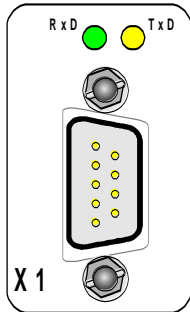

X1 - 9 pole SUB-D connector (male)	
LED	Meaning
RxD	LED green - receiving serial data
TxD	LED yellow - transmitting serial data
Pin	Signal
1	n.c.
2	RS232c (V.24) RXD
3	RS232c (V.24) TXD
4	n.c.
5	GND
6	RS422 (V.11) TxD+
7	RS422 (V.11) TxD-
8	RS422 (V.11) RxD+
9	RS422 (V.11) RxD-

TxD+ / RxD+ : high active
 TxD- / RxD- : low active
 n.c. = not connected

2.1.2 Optical Fiber Connection

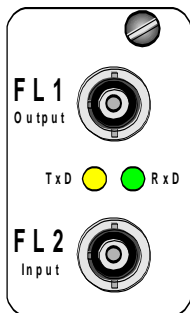

FL1 / FL2 - optical fiber ST design	
LED	Meaning
TxD	LED yellow - transmitting serial data
RxD	LED green - receiving serial data
Optical fiber component	
FL1	Optical fiber transmitter
FL2	Optical fiber receiver

2.2 Converter 4800AC-04/OC / 4800DC-04/OC (Optical Fiber ⇔ 3x Optocoupler)

Device 4800xx-04/OC is an optical fiber to optocoupler converter. With this converter, pulses can be transmitted over optical fiber and then emitted over optocoupler outputs.

Housing

Housing type: 1 (**Chapter 6.7 Dimensions - DIN Rail Housing**)

Connection

- The optical fiber receiver (FL) is of the ST design.
- The 3 optocoupler outputs are available on the 9-pole SUB-D male connector X1.
- Power input is via the respective connector depending on whether the power supply is AC or DC (see **Chapter 4 Power Supply**).

Status Display

- The optical fiber receiver has a status LED (RxD - green) which displays the current operating status of the optical fiber component.
- Each of the 3 optocouplers has a separate status LED which displays the interconnection of the respective optocoupler.

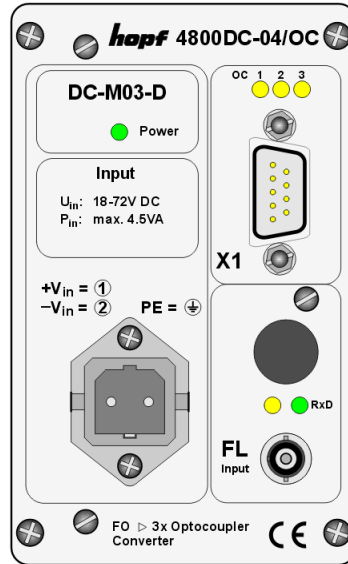
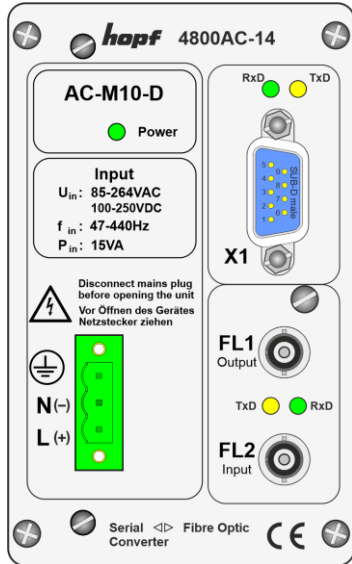

2.2.1 Optocoupler Connection

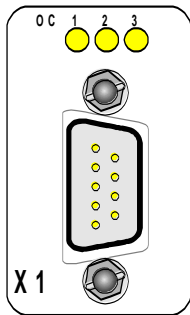

X1 - 9 pole SUB-D connector (male)	
LED	Meaning
1	LED yellow - Optocoupler 1 interconnected
2	LED yellow - Optocoupler 2 interconnected
3	LED yellow - Optocoupler 3 interconnected
Pin	Signal
1	n.c.
2	OC3-
3	OC2+
4	n.c.
5	OC1-
6	OC3+
7	n.c.
8	OC2-
9	OC1+

n.c. = not connected

2.2.2 Optical Fiber Connection

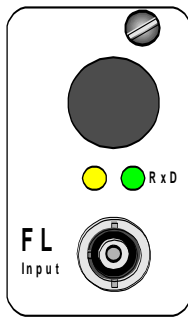

FL – optical fiber ST design	
LED	Meaning
---	LED yellow - n.c.
RxD	LED green - receiving pulses
Optical fiber component	
---	---
FL	Optical fiber receiver

2.3 4800AC-11 / 4800DC-11 (RS422 ↔ RS232) Converter

Device 4800xx-11 is a full duplex RS422 to RS232 interface converter.

Housing

Housing type: 1 (**Chapter 6.7 Dimensions - DIN Rail Housing**)

Connection

- The RS422 signals are available on the 9-pole SUB-D male connector X1.
- The RS232 signals are available on the 9-pole SUB-D male connector X2.
- Power input is via the respective connector depending on whether the power supply is AC or DC (see **Chapter 4 Power Supply**)

Status Display

- The RS422 transmission and reception lines both have a status LED (TxD – yellow and RxD - green) which displays the current operating status of the transmission and reception lines.
- The RS232 transmission and reception lines both have a status LED (TxD - yellow und RxD - green) which displays the current operating status of the transmission and reception lines.

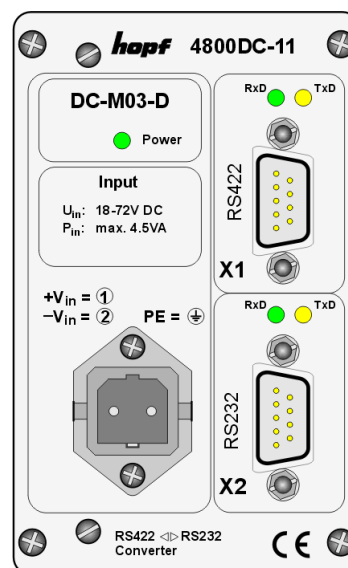
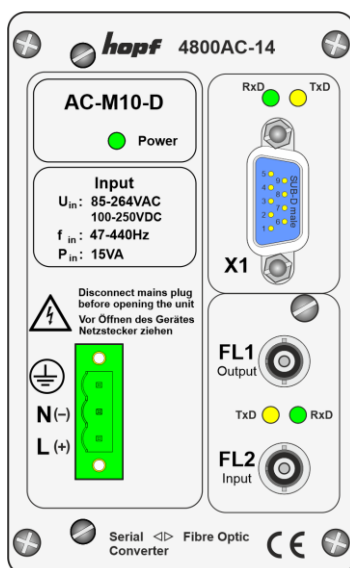

2.3.1 RS422 Connection

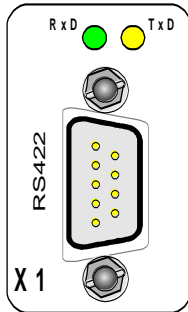

X1 - 9 pole SUB-D connector (male)	
LED	Meaning
RxD	LED green - receiving serial data
TxD	LED yellow - transmitting serial data
Pin	Signal
1	n.c.
2	n.c.
3	n.c.
4	n.c.
5	GND
6	RS422 (V.11) TxD+
7	RS422 (V.11) TxD-
8	RS422 (V.11) RxD+
9	RS422 (V.11) RxD-

TxD+ / RxD+ : high active
 TxD- / RxD- : low active
 n.c. = not connected

2.3.2 RS232 Connection

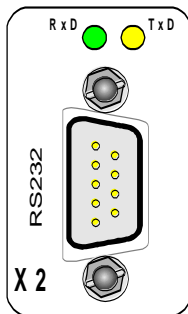

X2 - 9 pole SUB-D connector (male)	
LED	Meaning
RxD	LED green - receiving serial data
TxD	LED yellow - transmitting serial data
Pin	Signal
1	n.c.
2	RS232c (V.24) RXD
3	RS232c (V.24) TXD
4	n.c.
5	GND
6	n.c.
7	n.c.
8	n.c.
9	n.c.

n.c. = not connected

3 Housing Installation

Signal Converter 4800 can be clipped to rails in accordance with EN 50 022 and is designed for horizontal mounting.

Installation Dimensions

The dimensions of the housings can be found in **Chapter 6.7 Dimensions - DIN Rail Housing**.

- Converter Type 4800xx-14 – Housing: TYPE 1
- Converter Type 4800xx-04/OC – Housing: TYPE 1
- Converter Type 4800xx-11 – Housing: TYPE 1



In order to guarantee satisfactory convection we recommend the following minimum distance from other modules:

- 5.0 cm in a vertical direction
- 1.0 cm in a horizontal direction

3.1 Mounting

Place the rail guide bar of the module against the lower edge of the rail, push the module upwards and clip into place at the top.

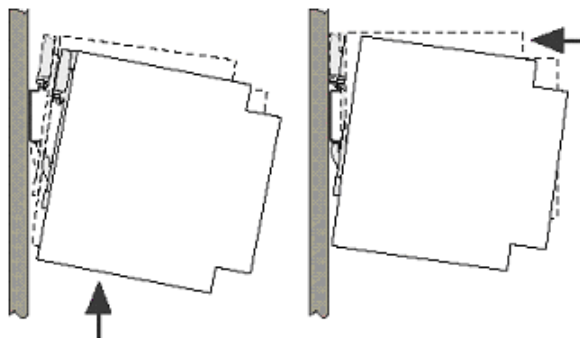

3.2 Demounting

Push the module upwards and then tip forward to remove from the rail.

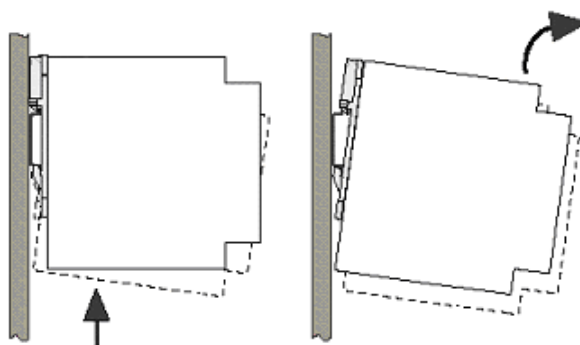

4 Power Supply

The rail mounted Signal Converter 4800 is available with both AC and DC power supply.

4.1 Grounding

The signal converter is grounded via the ground wire in the power supply cable.

4.2 AC Power Supply – Power Supply Unit AC-M05-D/AC-M10-D

The standard AC power supply (AC-M10-D) unit for the converter is described here; however the connection data on the nameplate of the respective device is always applicable.

Pay attention to the following when connecting the power supply:

- Correct voltage type (AC or DC)
- Voltage amount

The power cable is connected via a plug-in 3-pole screw connection with casing.

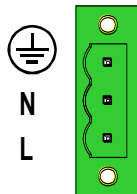

Connecting the incorrect voltage can damage the Signal Converter 4800.

4.2.1 Safety and Warning Instructions

Please read these instructions thoroughly to facilitate safe operation of the device and to use all of its functions.



Warning: Never work on live equipment! Danger to life!

Signal Converter 4800 is a built-in device. Installation and commissioning may only be carried out by suitable specialist personnel. In doing so the respective country-specific regulations (e.g. VDE, DIN) must be observed.

In particular, before commissioning please ensure that:

- The power connection has been installed correctly and there is guaranteed protection against electric shock.
- The ground wire is connected.
- All power cables are correctly fused and sized.
- All output lines are sized in accordance with the max. output current of the device or are specially fused.
- Sufficient convection is guaranteed.

The device contains components carrying life-threatening voltage and a high amount of stored energy.

4.2.2 Power Supply Unit Specifications

All specifications regarding the AC power supply can be found in **Chapter 6.2 AC - Power Supply**.

4.2.3 Power Connection and Control Display

Connection and operation of the Signal Converter 4800 power supply.

4.2.3.1 Connection to various power networks

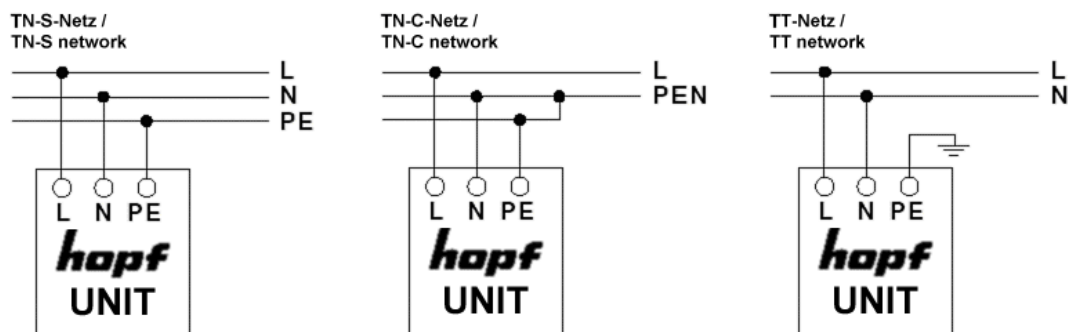

4.2.3.2 Power cable connection

The power cable is connected via a plug-in 3-pole screw connection. The following cable cross-sections can be connected to the input plug:

	Fixed [mm ²]	Flexible [mm ²]	AWG	Starting moment [Nm]
L, N, 	0.2-2.5	0.2-2.5	24-12	0.5 – 0.6

For a reliable and secure contact:

Strip the insulation by 8mm

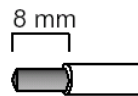

The connector must always be mounted using the housing and strain relief fitting provided.

4.2.3.3 Voltage Input / Fuse Protection

The 85-264VAC / 100-250VDC connection is made via the plug-in screw connections L, N and .

Primary Side Fuse Protection

The device must be installed in accordance with the provisions of EN 60950. There must be a suitable isolating device external to the power supply capable of switching the device off.

The primary side line protection, for example, is suitable for this purpose.

Further equipment protection is not required because the device is fused internally.

Recommended External Fuse

Automatic cut-out 6 A or 10 A, characteristic B (or equivalent in function).

A suitable external fuse is required for DC applications.



If the internal fuse trips it is highly likely that the device is faulty. In this case the equipment should be checked at the factory.

4.2.3.4 Power LED

The green Power LED allows the function of the power supply unit on the device to be checked.

LED lights	Normal power supply operation
LED off	No power supply is available or the device is faulty.

4.3 DC Power Supply – Power Supply Unit DC-M03-D

The system's standard DC power supply unit is described here; however the connection data on the nameplate of the respective device is always applicable.



Make sure that the external voltage source is switched off. When connecting the power supply, ensure that the polarity and ground connection are correct.

+V_{in} = ①
-V_{in} = ② PE = ⊕

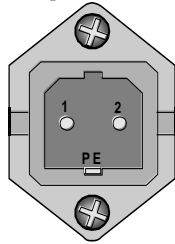

The power supply cable is connected to the Signal Converter 4800 by means of a 2-pole connector with additional ground connection and interlock:

+V_{in}: Positive pole (contact 1)
-V_{in}: Negative pole (contact 2)
PE: Ground



Connecting the incorrect voltage can damage the Signal Converter 4800.



Grounding:

The negative pole (-V_{in}) and the ground (PE) are connected together as standard on the system side.

4.3.1 Power Supply Unit Specifications

All specifications regarding the DC power supply can be found in **Chapter 6.3 DC - Power Supply**.

4.3.2 Fuse Protection

When connecting the Signal Converter 4800, make sure that there is adequate fuse protection on the power supply.

Consult the technical data on the nameplate of the device for details.

4.3.3 Polarity Reversal Protection

Signal Converter 4800 with DC power supply has polarity reversal protection. The protection prevents the device from damage if the DC power supply is connected with reverse polarity. Protection is realized by means of a diode.

4.3.3.1 Power LED

The green Power LED allows the function of the power supply unit on the device to be checked.

LED lights	Normal power supply operation
LED off	No power supply is available or the device is faulty.

5 Commissioning

This chapter describes the commissioning of the Signal Converter 4800.

5.1 General Procedure

Commissioning is structured as follows:

- Check the cabling:
 - Grounding
 - Power supply
 - Signal feed
- Switch on the external power supply
- Check the signal conversion function

5.2 Switch on the Operating Power Supply

The converter has no external power supply switch. The converter is activated by the external power supply source.

AC Power Supply:

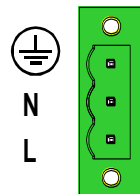

Switch on the external power supply source.

DC Power Supply:

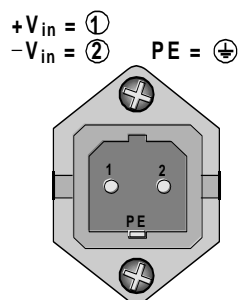

Switch on the external power supply source.

6 Technical Data



hopf reserves the right to modify hardware and software at any time.

Custom-made production:

Modifications can be made to hardware and software in accordance with customer specifications.

6.1 General

General Data	
Installation location:	On horizontal 35mm rail in accordance with EN 50 022
Protection type of the housing:	IP40
Protection class:	I, with PE connection
MTBF:	> 400 000 h
Housing design:	Aluminium, closed
Housing dimensions:	See Chapter 6.7 Dimensions - DIN Rail Housing
Weight:	approx. 0.6kg

Ambient Conditions		
Temperature range:	Operation:	0°C to +55°C
	Storage:	-20°C to +75°C
Humidity:		max. 95%, no condensation

CE compliant to EMC Directive 89/336/EEC and Low Voltage Directive 73/23/EEC	
Safety / Low Voltage Directive:	EN 60950-1:2001 + A11 + corrigendum
EN 61000-6-4:	
EMC (Electromagnetic Compatibility) Stability:	EN 61000-4-2 /-3/-4/-5/-6/-11
EN 61000-6-2:	EN 61000 -3 -2 /-3
Interference voltage: EN 55022	EN 55022 Class B
Interference radiation: EN 55022	EN 55022 Class B

6.2 AC - Power Supply

Internal Power Supply (Only wide input range)	hopf Type: AC-M05-D	hopf Type: AC-M10-D
---	-----------------------------------	-----------------------------------

Input Data		
Input voltage range	85-264VAC 100-250VDC	85-264VAC 100-250VDC
Frequency	47-440Hz 0 Hz	47-440Hz 0 Hz
Current consumption (at nominal values)	approx. 0.15A (100VAC) 0.10A (200VAC)	approx. 0.30A (100VAC) 0.20A (200VAC)
Inrush current	typ. 15A (I _o = 100%) 100VAC typ. 30A (I _o = 100%) 200VAC	typ. 15A (I _o = 100%) 100VAC typ. 30A (I _o = 100%) 200VAC
Hold-up time at nominal load	> 20msec. (> 100VAC)	> 20msec. (> 100VAC)
Start-up time after connected mains voltage	< 1 sec.	< 1 sec.
Transient overvoltage protection	Overvoltage protection III (EN 60664-1)	Overvoltage protection III (EN 60664-1)
Protection supply, internal	400 mA slow blow (device protection)	400 mA slow blow (device protection)
Recommended back-up fuse (AC)	Circuit breaker 6A, 10A characteristics B (EN 60898)	Circuit breaker 6A, 10A characteristics B (EN 60898)
Leakage current against PE	< 0.5mA (60Hz, according to EN 60950)	< 0.5mA (60Hz, according to EN 60950)
Input isolation voltage / PE	2000VAC, 1 minute, leakage current = 10mA, 500VDC, 50MΩ min. (at room temperature)	2000VAC, 1 minute, leakage current = 10mA, 500VDC, 50MΩ min. (at room temperature)

Output Data (only internal)		
Internal nominal output voltage	5VDC	5VDC
Nominal output current I _N 0° C ... +55° C	1A (U _{OUT} = 5VDC)	2A (U _{OUT} = 5VDC)
Efficiency	> 77%	> 74%
Function Display (Power LED)	LED green	LED green

6.3 DC - Power Supply

Internal Power Supply	hopf type: DC-M03-D (short)
------------------------------	---

Input data	
Input voltage range:	18-72VDC
Power consumption (at nominal values):	24VDC / 0.2A or 48VDC / 0.1A
Isolation voltage input / output:	1500VDC

Output Data (internal only)	
Internal nominal output voltage:	5VDC
Nominal output current I _N 0°C ... +55°C:	0.66A (U _{OUT} = 5VDC)
Efficiency:	> 82%
Function display (power LED):	Green LED

6.4 Optical Fiber Components

Optical Fiber General	
Supported multi-mode optical fiber cable types:	50/125µm, 62.5/125µm, 100/140µm or 200µm HCS® fiber

Optical fiber outputs: λ = 820nm, connector type: ST (bayonet) – for T=+25°C	
Optical output power P _{OUT} [dBm] to multi-mode optical fiber cable (Length = 1m, 50/125µm):	P _{OUT} [dBm] = -15dBm (± 0.2dBm) ⇔ P _{OUT} [µW] = 32µW (± 1.5µW)
Optical output power P _{OUT} [dBm] to multi-mode optical fiber cable (Length = 2.5m, 62.5/125µm):	P _{OUT} [dBm] = -11dBm (± 0.2dBm) ⇔ P _{OUT} [µW] = 80µW (± 3.6µW)
Optical output power P _{OUT} [dBm] to multi-mode optical fiber cable (Length = 2000m, 62.5/125µm):	P _{OUT} [dBm] = -18dBm (± 0.2dBm) ⇔ P _{OUT} [µW] = 16µW (± 0.8µW)
Max. transmission frequency:	<= 10MHz
Switch-on/off delay:	< 10nsec.
Max. serial data communication:	512 kBaud

Optical fiber inputs: λ = 820nm, connector type: ST (bayonet) – for T=+25°C	
Min. optical received power:	P _{IN} [dBm] = -25dBm (± 0.2dBm) ⇔ P _{IN} [µW] = 3.2µW (± 0.15µW)
Max. optical received power (overload):	P _{IN} [dBm] = -9dBm (± 0.2dBm) ⇔ P _{IN} [µW] = 126µW (± 6µW)
Max. reception frequency:	<= 5MHz
Signal delay:	< 75nsec. (at -21dBm)
Max. serial data communication:	512 kBaud



The max. allowable length of the multi-mode 62.5/125µm optical fiber cable between two optical fiber components is 2000m (applicable to **hopf** devices). Pay attention to the optical output power or received power when using other optical fiber types.

6.5 RS232/RS422 Signal Inputs/Outputs

RS422 / RS232 Signal Outputs	
Serial full duplex interfaces (no handshake):	via 9-pole SUB-D male connector
Max. serial data communication:	512 kBaud

The interface modules can be supplied with electrical isolation as an option.

6.6 Optocoupler

Optocoupler	
Max. switching capacity, resistive load:	60VDC / 200mA
Switch-on/off delay:	150 / 100 μ sec. at 20mA switching current
Isolation voltage:	500VDC 1000M Ω min.

6.7 Dimensions - DIN Rail Housing

