

Industriefunkuhren



Additional Technical Manual

for DIN Rail Modules

4465AC/4475AC/4800AC/6870AC/6875AC

with

AC Power Supply

Type AC-M05-D / AC-M10-D

ENGLISH

Version: 01.03 – 17.06.2021

Downloading Technical Descriptions

All current descriptions of our products are available free of charge via our homepage on the Internet.

Homepage: <http://www.hopf.com>

E-Mail: info@hopf.com

Symbols and Characters



Operational Reliability

Disregard may cause damages to persons or material.



Functionality

Disregard may impact function of system/device.



Information

Notes and Information.



Safety regulations

The safety regulations and observance of the technical data serve to ensure trouble-free operation of the device and protection of persons and material. It is therefore of utmost importance to observe and compliance with these regulations.

If these are not complied with, then no claims may be made under the terms of the warranty and no liability will be assumed for any ensuing damage.



Safety of the device

This device has been manufactured in accordance with the latest technological standards and approved safety regulations

The device should only be put into operation by trained and qualified staff. Care must be taken that all cable connections are laid and fixed in position correctly. The device should only be operated with the voltage supply indicated on the identification label.

The device should only be operated by qualified staff or employees who have received specific instruction.

If a device must be opened for repair, this should only be carried out by employees with appropriate qualifications or by **hopf**Elektronik GmbH.

Before a device is opened or a fuse is changed all power supplies must be disconnected.

If there are reasons to believe that the operational safety can no longer be guaranteed the device must be taken out of service and labeled accordingly.

The safety may be impaired when the device does not operate properly or if it is obviously damaged.

CE-Conformity



This device fulfils the requirements of the EU directive 2014/30/EU "Electromagnetic Compatibility" and 2014/35/EU "Low Voltage Equipment".

Therefore the device bears the CE identification marking
(CE = Communautés Européennes = European communities)

The CE indicates to the controlling bodies that the product complies with the requirements of the EU directive - especially with regard to protection of health and safety for the operator and the user - and may be released for sale within the common markets.

Contents	Page
1 Variations to Standard Manuals of the Devices	7
2 Housing Installation	8
2.1 Mounting	8
2.2 Demounting.....	8
3 Power Supply	9
3.1 Power Supply Unit Specifications	9
3.2 Safety and Warning Instructions.....	10
3.3 Power Connection and Control Display	11
3.3.1 Connection to Several Power Networks	11
3.3.2 Connection of the Power Cable	11
3.3.3 Voltage Input / Fuse Protection.....	12
3.3.4 Power LED.....	12
4 Technical Data	13
4.1 General	13
4.2 Power Supply hopf DIN Rail Module.....	13
4.3 Power Supply	13
4.4 Dimensions – Rail Mounting Housing	14

1 Variations to Standard Manuals of the Devices



This additional manual is valid for the DIN Rail Modules 4465AC, 4475AC, 4800AC, 6870AC and 6875AC with AC power supply **AC-M05-D** or AC power supply **AC-M10-D**.

This manual **only** contains the specification for the voltage supply for the different modules and replaces the technical specifications of the according manuals for those devices.

Changes in comparison to the standard with DC voltage input:

- The voltage input via the connector X1 is not applicable. The upper two screws of the screw terminal of X1 have no function (n.c. – not connected).
- The dimension of the housing changes from Type 1 to Type 2 (dimensions see **chapter 4.4 Dimensions – Rail Mounting Housing**).
- The AC voltage input is made via the 3-pole pluggable screw terminal labeled with L, N and PE. The nominal input voltage is 85-264VAC.
- The earthing of the DIN Rail Module is made via the PE contact of the 3-pole pluggable screw terminal.

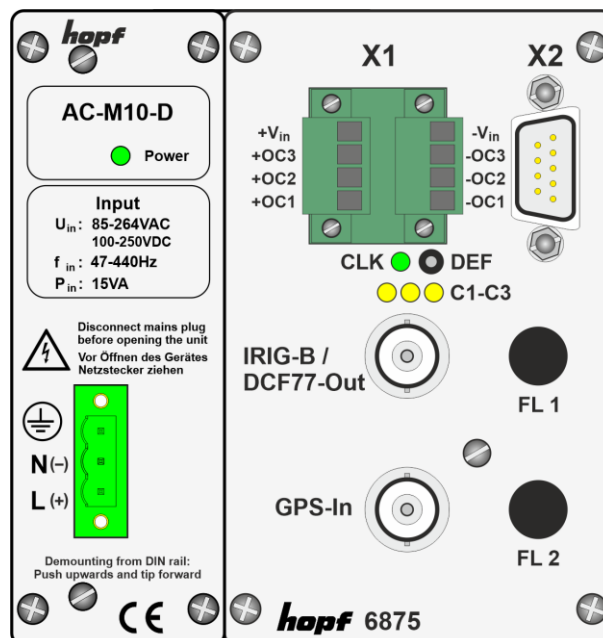

Example: DIN Rail Module 6875AC with AC Power Supply AC-M10-D

2 Housing Installation

The DIN Rail Module can be clipped on to all DIN rails per DIN EN 50 022 and is designed for horizontal mounting.

Installation dimensions

The dimensions of the housing can be found in **Chapter 4.4 Dimensions – Rail Mounting Housing**.

- 4465AC with integrated AC power supply ⇒ **Housing TYPE 2**
- 4475AC with integrated AC power supply ⇒ **Housing TYPE 2**
- 4800AC with integrated AC power supply ⇒ **Housing TYPE 2**
- 6870AC with integrated AC power supply ⇒ **Housing TYPE 2**
- 6875AC with integrated AC power supply ⇒ **Housing TYPE 2**



In order to guarantee satisfactory convection we recommend the following minimum distance from other modules:

- 5.0 cm in a vertical direction
- 1.0 cm in a horizontal direction

2.1 Mounting

Place the rail guide bar of the module against the lower edge of the DIN rail, push the module upwards and clip into place at the top.

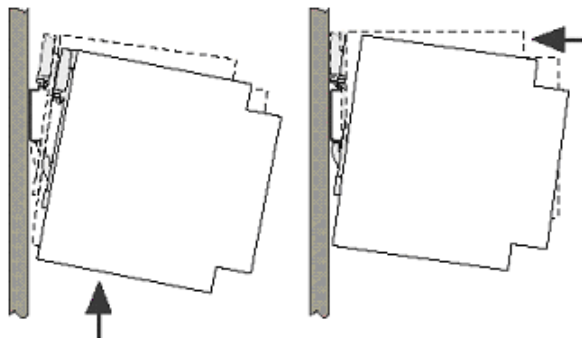

2.2 Demounting

Push the module upwards and then tip forward to remove from the DIN rail.

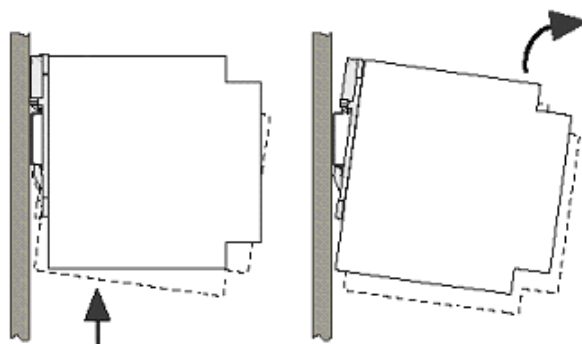

3 Power Supply

The DIN Rail Module has an AC power supply unit with a wide input range.

3.1 Power Supply Unit Specifications

Internal Power Supply (Only wide input range)	<i>hopf</i> Type: AC-M05-D	<i>hopf</i> Type: AC-M10-D
Input Data		
Input voltage range	85-264VAC 100-250VDC	85-264VAC 100-250VDC
Frequency	47-440Hz 0 Hz	47-440Hz 0 Hz
Current consumption (at nominal values)	approx. 0.15A (100VAC) 0.10A (200VAC)	approx. 0.30A (100VAC) 0.20A (200VAC)
Inrush current	typ. 15A (I _o = 100%) 100VAC typ. 30A (I _o = 100%) 200VAC	typ. 15A (I _o = 100%) 100VAC typ. 30A (I _o = 100%) 200VAC
Hold-up time at nominal load	> 20msec. (> 100VAC)	> 20msec. (> 100VAC)
Start-up time after connected mains voltage	< 1 sec.	< 1 sec.
Transient overvoltage protection	Overvoltage protection III (EN 60664-1)	Overvoltage protection III (EN 60664-1)
Protection supply, internal	400 mA slow blow (device protection)	400 mA slow blow (device protection)
Recommended back-up fuse (AC)	Circuit breaker 6A, 10A characteristics B (EN 60898)	Circuit breaker 6A, 10A characteristics B (EN 60898)
Leakage current against PE	< 0.5mA (60Hz, according to EN 60950)	< 0.5mA (60Hz, according to EN 60950)
Input isolation voltage / PE	2000VAC, 1 minute, leakage current = 10mA, 500VDC, 50MΩ min. (at room temperature)	2000VAC, 1 minute, leakage current = 10mA, 500VDC, 50MΩ min. (at room temperature)

Output Data (only internal)		
Internal nominal output voltage	5VDC	5VDC
Nominal output current I _N 0° C ... +55° C	1A (U _{OUT} = 5VDC)	2A (U _{OUT} = 5VDC)
Efficiency	> 77%	> 74%
Function Display (Power LED)	LED green	LED green

3.2 Safety and Warning Instructions

Please read these instructions thoroughly to facilitate safe operation of the equipment and to use all of its functions.



Warning: Never work on live equipment on open devices! Danger to life!

The **hopf** DIN Rail Module is a built-in device. It is protected for installation in service access areas. Installation and commissioning may only be carried out by suitable specialist personnel. In doing so the respective country-specific regulations (e.g. VDE, DIN) are to be observed.

In particular, before commissioning please ensure that:

- The power connection has been installed correctly and there is guaranteed protection against electric shock!
- The device can be switched off externally to the power supply, in accordance with the provisions of EN 60950 (e.g. via the primary-side line protection)!
- The ground wire is connected!
- All power cables are correctly fused and sized!
- All output lines are sized in accordance with the max. output current of the device or are specially fused!
- Sufficient convection is guaranteed!

The housing can become very hot dependent on the environment temperature and the load on the device!

The device contains components with life-threatening voltage and a high amount of stored energy!

3.3 Power Connection and Control Display

Connection and operation of the **hopf** DIN Rail Module power supply.

3.3.1 Connection to Several Power Networks

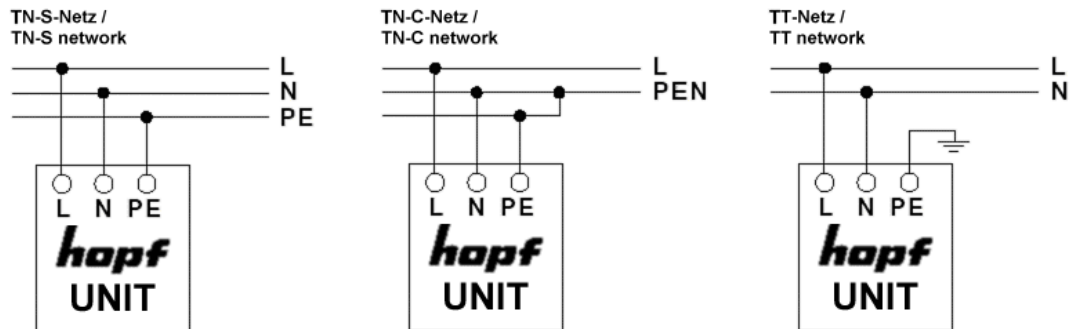

3.3.2 Connection of the Power Cable

The power cable is connected via a 3-pole pluggable screw terminal. The following cable cross-sections can be connected to the input plug:

	Fixed [mm ²]	Flexible [mm ²]	AWG	Starting moment [Nm]
L, N, 	0.2-2.5	0.2-2.5	24-12	0.5 – 0.6

For a reliable and secure contact:

Strip the insulation by 8 mm

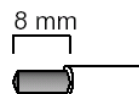

The connector must always be mounted using the housing and strain relief fitting provided.

3.3.3 Voltage Input / Fuse Protection

The 85-264VAC connection is made via the plug-in screw connections L, N and .

Primary Side Fuse Protection

The device must be installed in accordance with the provisions of EN 60950. There must be a suitable separating device external to the power supply capable of switching the device off.

The primary side line protection, for example, is suitable for this purpose.

Further equipment protection is not required because the device is fused internally.

Recommended External Fuse

Automatic cut-out 6A or 10A, Characteristic B (or equivalent in function).

A suitable external fuse is required for DC applications.



If the internal fuse trips (device protection) it is highly likely that the device is faulty. In this case the equipment should be checked at the factory.

3.3.4 Power LED

The green Power LED enables functions to be evaluated on-site at the control cabinet.

LED lights	Normal power supply operation
LED off	No power supply is available or the device is faulty.

4 Technical Data

4.1 General

The technical data in this document are only valid in connection with the technical manual of the according module.

All specified data in this document replaces those of the appropriate technical manual of the module.

Regarding all other articles the technical manual of the module is the relevant document.

4.2 Power Supply *hopf* DIN Rail Module

General Data	
Installation position	On horizontal 35mm DIN rail per DIN EN 50 022
Protection Type of the housing	IP40
Protection Class	I, with PE connection
MTBF	> 300,000h
Type of housing	Aluminium, closed
Dimensions (W x H x D) + DIN Rail	100 x 105 x 130mm (Type 2)
Weight	approx. 1.05kg

Climatic Data	
Environmental temperature	Operation: 0° C ... +55° C Storage: -20° C ... +75° C
Humidity	Up to 90% at +25° C, no condensation

CE compliant to EMC Directive 89/336/EEC and Low Voltage Directive 73/23/EEC	
Safety - Low Voltage Directive	DIN EN 60950-1:2001 + A11 + Corrigendum
EN 61000-6-4:	
EMC (Electro-Magnetic Compatibility) Stability	EN 61000-4-2 /-3/-4/-5/-6/-11
EN 61000-6-2:	EN 61000 -3 -2 /-3
Interference Voltage EN 55022	EN 55022 Class B
Interference Voltage EN 55022	EN 55022 Class B

4.3 Power Supply

Internal Power Supply (with wide input range)	<i>hopf</i> type: AC-M05-D / AC-M10-D
Power consumption AC-M05-D	max. 6 VA
Power consumption AC-M10-D	max. 15 VA

4.4 Dimensions – Rail Mounting Housing

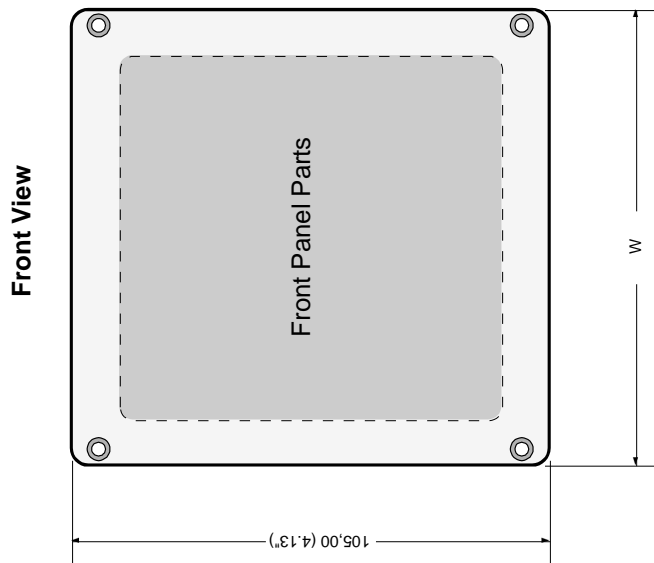
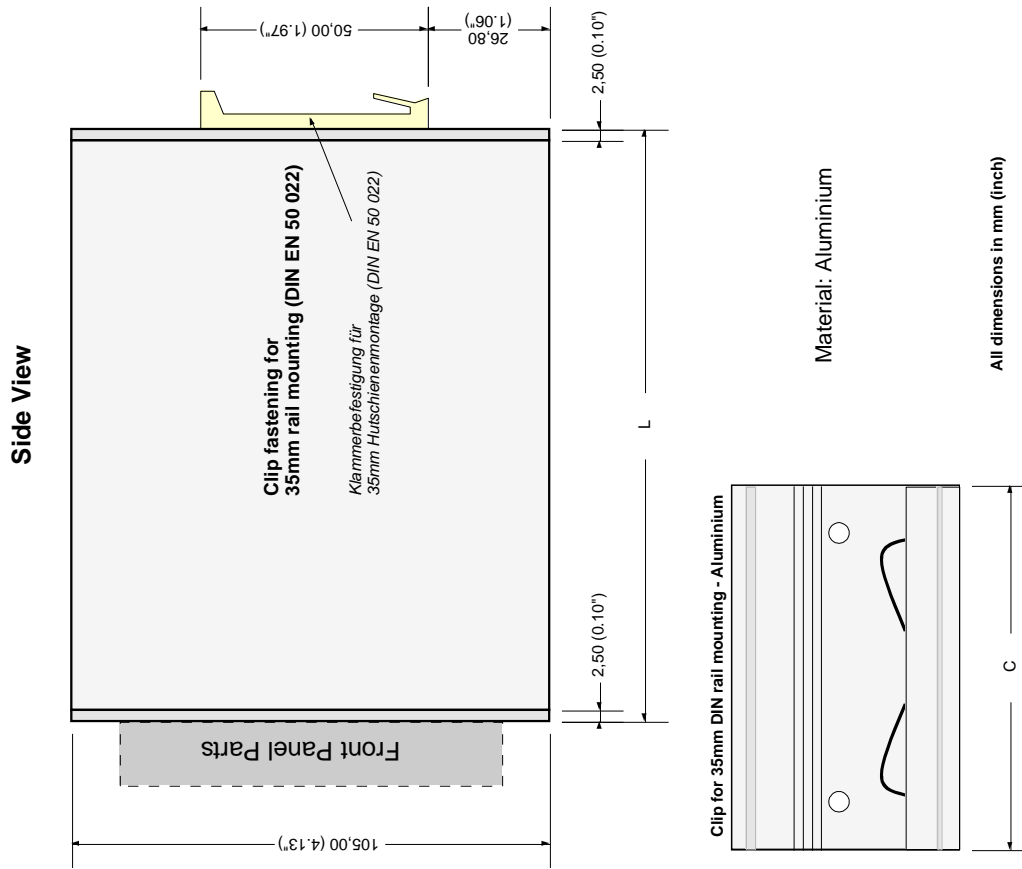

TYPE	(L)length	(W)idth	(C)lip
1	130 (5.12")	64,5 (2.54")	40,0 (1.57")
2	130 (5.12")	100,0 (3.94")	80,0 (3.15")
3	130 (5.12")	135,0 (5.31")	80,0 (3.15")
4	175 (6.89")	64,5 (2.54")	40,0 (1.57")
5	175 (6.89")	100,0 (3.94")	80,0 (3.15")
6	175 (6.89")	135,0 (5.31")	80,0 (3.15")